

MODEL No:

1492-04A-9

NOTE: Information herein is believed by Southwest Microwave, Inc. to be accurate. However, Southwest Microwave assumes no responsibility for any omissions or errors or inaccuracies for its use or for any infringements of patents or other rights of third parties that may result from its use. Data is intended for informational purpose only and does not constitute a contract of sale or any express or implied warranty, including any warranty of merchant ability or fitness for a particular purpose.

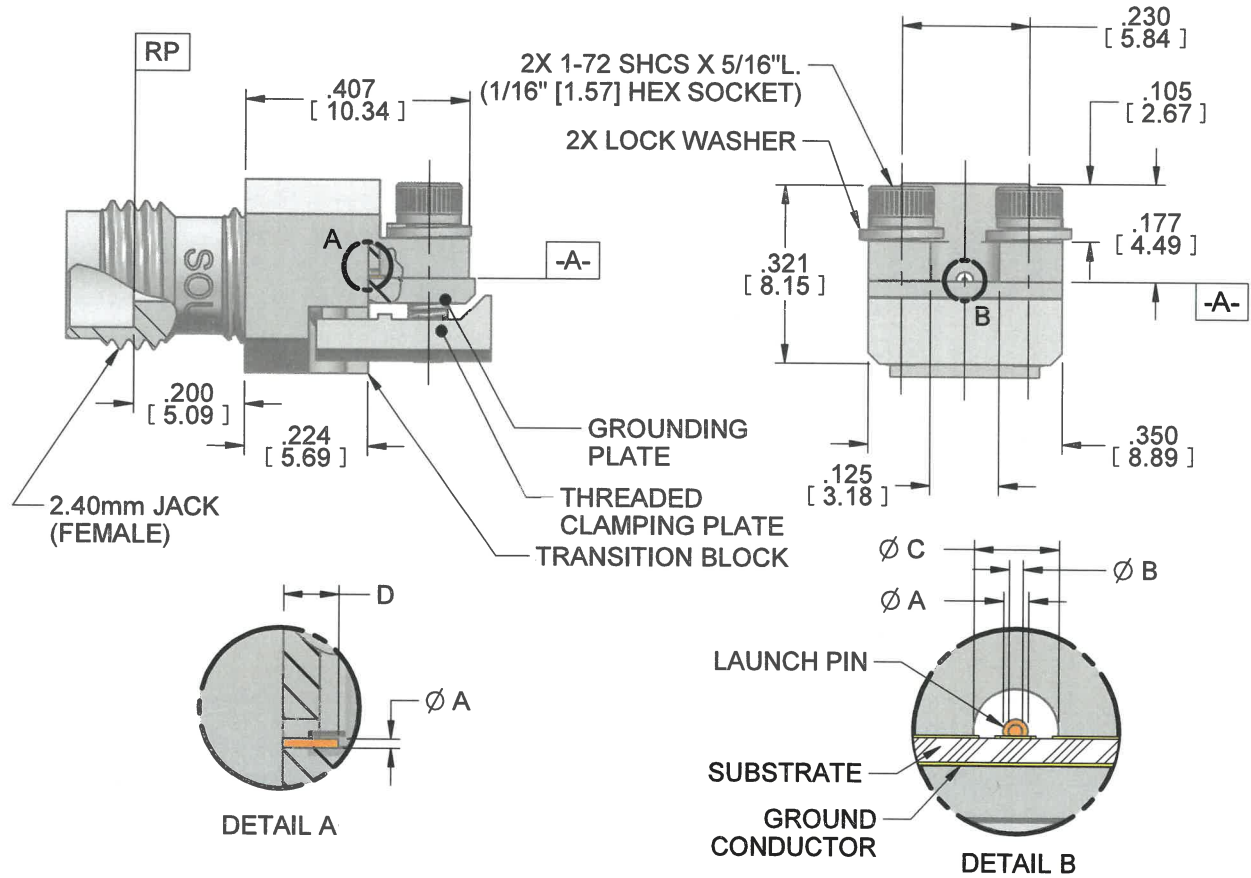
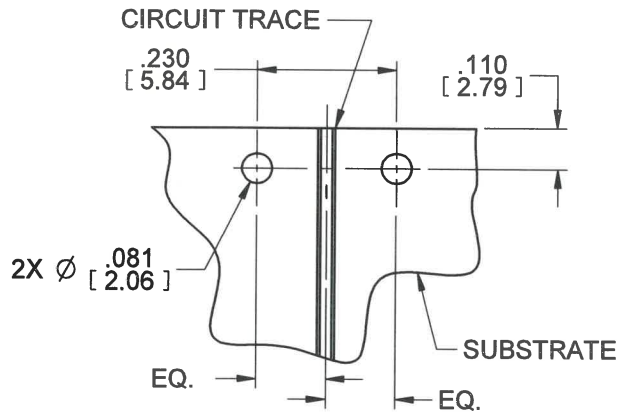

HOUSING:	STEEL, CRES ALLOY UNS 30300 PER ASTM A582 PASSIVATED PER ASTM A967-99
CONTACT:	BeCu UNS C17300 PER ASTM B196 GOLD PLATE PER ASTM B488
CAPTURE BEAD:	ULTEM 1000 PER ASTM D5205
DIELECTRIC:	KEL-F (PCTFE) PER ASTM D1430
ITEM	MATERIAL & FINISH
2.40mm CONNECTOR	

TRANSITION BLOCK, GROUNDING PLATE, THREADED CLAMPING PLATE:	C360 BRASS ALLOY UNS C36000 PER ASTM B16. NICKEL PLATE PER AMS 2404B
LAUNCH PIN:	BeCu UNS C17300 PER ASTM B196 GOLD PLATE PER MIL-DTL-45204
TRANSITION BLOCK DIELECTRIC:	VIRGIN PTFE FLUOROCARBON PER ASTM D1710, TYPE 1 GRADE 1, CLASS B
ITEM	MATERIAL & FINISH
TRANSITION BLOCK	

Model	Ø A	Ø B	Ø C	D
1492-04A-9	.005	.009	.0295	.030

1. ALL DIMENSIONS ARE IN INCHES. ALL ANGLES ARE IN DEGREES. DIMENSIONS SHOWN IN BRACKETS [XXX] ARE IN MILLIMETERS.

NOTES: UNLESS OTHERWISE SPECIFIED.

REV A	RELEASE	APRVD. <i>JW</i>	DATE: <i>07/10/17</i>	TITLE 1492-04A-9 2.40mm JACK (FEMALE) END LAUNCH CONNECTOR SUPER SMALL END LAUNCH
 Southwest Microwave, Inc. 9055 South McKemy Street Tempe, Arizona 85284-2946 Telephone (480) 783-0201 Fax (480) 783-0360		DRN BY: MGD	DATE: 06/28/17	REV.
		DWG. NO. 79Y63707		A
SHEET: 1 OF 1				