

EMD1710QFN4 Low Noise Amplifier

2-20 GHz GaAs PHEMT MMIC Distributed Amplifier



Eclipse Microdevices EMD1710 is a GaAs MMIC PHEMT Distributed general purpose Low Noise Amplifier. This LNA has a small signal gain of 12 dB with noise figure less than 2.0 dB at 10 GHz. This device is ideal for applications that requires a typical P1dB output power of +18dBm up to 12 GHz, while requiring only 83mA from a + 5 Volt supply. The EMD1710 is available in a small RoHS compliant 4mm QFN leadless package with excellent RF and thermal properties, ideal for commercial and industrial applications.

Technical Characteristics

Product Features

2.0 dB Noise Figure Gain @ 10 GHz
12.5 dB Gain @ 10 GHz
+18.5 dBm P1dB Output Power @ 10 GHz
Low cost QFN 4mm leadless RoHS compliant/hermetically sealed
+5.0V @ 83mA typical supply voltage

Max. Ratings

RF Input Power:	+18.0 dBm
Drain Voltage (Vdd):	+8.0 VDC
Gate Voltage (Vgg):	-2.0 to 0 VDC
Max. T _j 85° C:	+110°C
Storage Temperature:	-55 to +150°
Operating Temperature:	-40 to +85°

Electrical Specifications @ +25°C, Vdd= 5.0, Ids= 83mA

Parameters	Freq. (GHz)	Min.	Typical	Max.	Units
Gain	2.0	12.5	13.1		dB
	8.0	11.5	12.1		dB
	14.0	11.5	12.6		dB
	20.0	12.8	13.2		dB
Gain Flatness	DC to 20.0 GHz		+/- 0.20	+/- 0.40	dB
	10.0 to 20.0		+/- 0.25	+/- 0.40	dB
Gain Variation Over Temperature				.02	dB/°C
Noise Figure	2.0		4.4		dB
	8.0		2.5		
	14.0		2.4		
	20.0		3.4		
Input Return Loss			11.0		dB
Output Return Loss			10.0		dB
1dB Compression Point	2.0		18.3		dBm
	8.0		18.9		dBm
	14.0		15.5		dBm
	20.0		15.2		dBm
Saturated Output Power	2.0		20.5		dBm
	8.0		20.5		dBm
	14.0		19.5		dBm
	20.0		19.0		dBm
3rd Order Intercept Point			28.0		dBm

About EclipseMDI

ECLIPSE MDI is located in San Jose, California. ECLIPSE has been developing high performance analog semiconductors for use in wireless radio frequency (RF), microwave, and millimeter wave for commercial and industrial applications. ECLIPSE has formed a strategic alliances - with foundries that feature leading state-of-the-art process technologies and with manufacturing facilities for high-volume production of innovative RFIC's.

EMD1710QFN4 Low Noise Amplifier

2-20 GHz GaAs PHEMT MMIC Distributed Amplifier



Outline Drawing

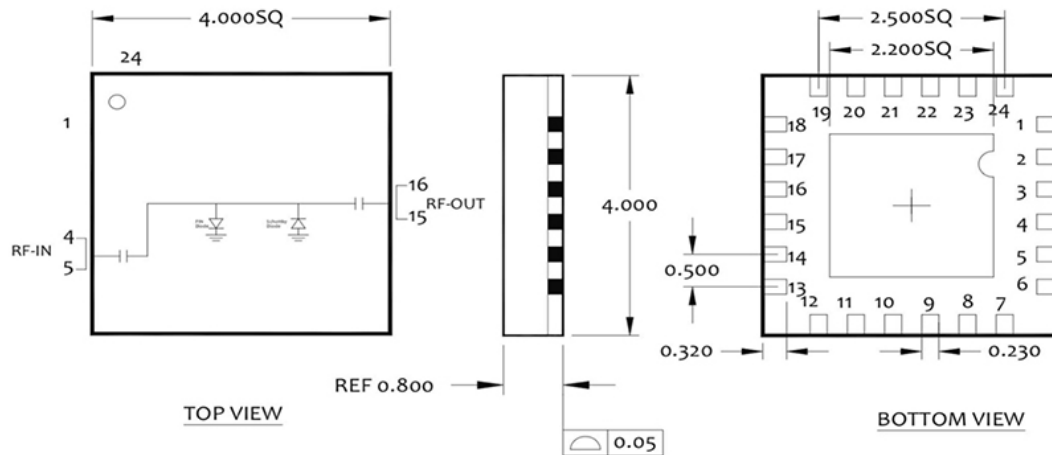

Functional block diagram

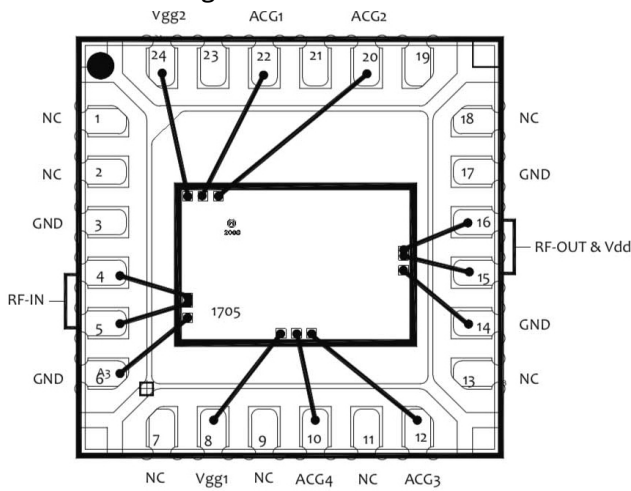

Recommended PCB layout

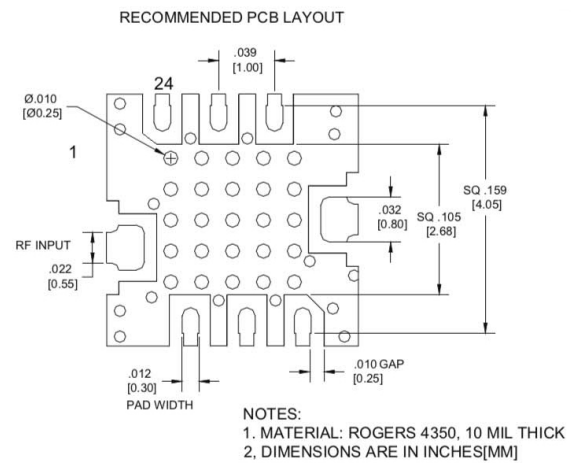

Application Circuit

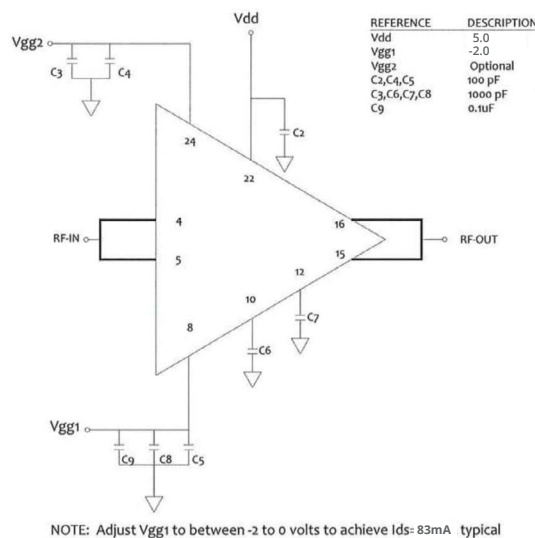

EMD1710QFN4 Low Noise Amplifier

2-20 GHz GaAs PHEMT MMIC Distributed Amplifier



S-parameters/Noise Figure

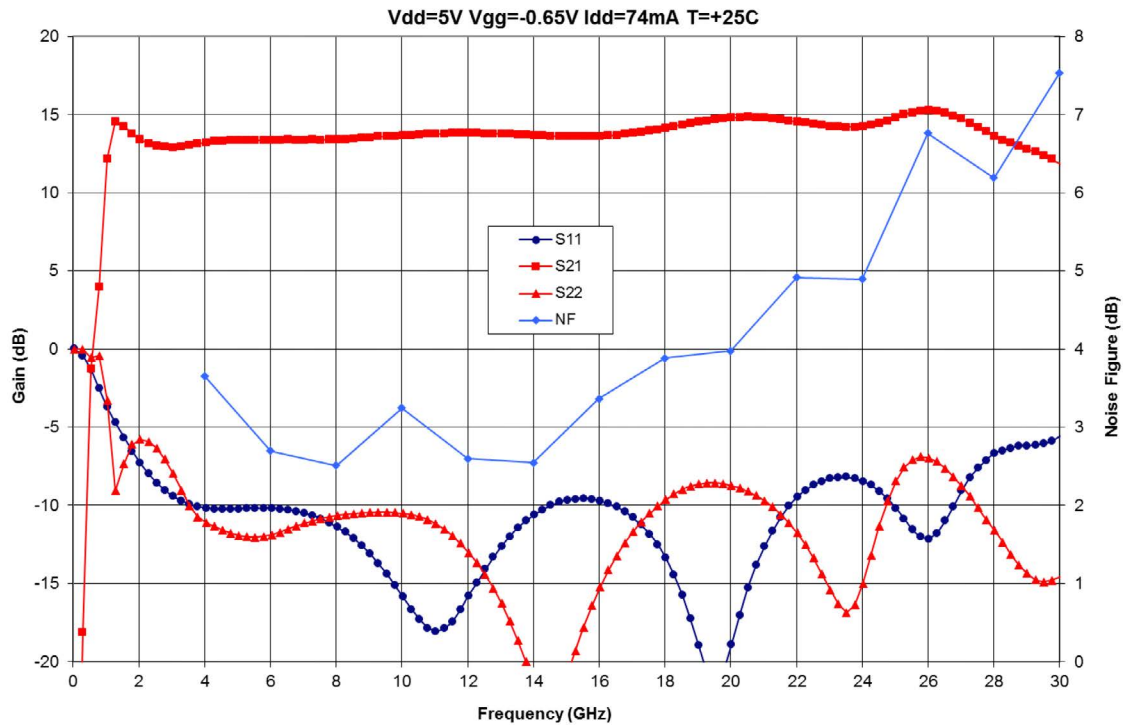

Power Out

