

PHASE COHERENT CHANNELS: 3GHz - 6GHz - 12GHz - 24GHz - 40GHz



CE
RoHS

The HSX Series offers exceptional phase noise and spectral purity performance as a multi-channel CW signal source. The compact 1U chassis allows for anywhere from 1x to 4x independently tunable channels (frequency / phase offset / amplitude) to optimize channel density within test system racks where real-estate is often crucial. Application specific frequency options can be configured to cover combinations of 10MHz to **3GHz, 6GHz, 12GHz, 24GHz and 40GHz**. Each broadband channel output provides an accurate dynamic range of up to +20dBm to -110dBm. Holzworth's unique multi-loop architecture provides the ultimate in frequency accuracy, channel-to-channel stability and phase coherency.

FULLY INDEPENDENT CHANNELS

Each RF output is driven by a separate, internally loaded synthesizer/attenuator module. Up to 4 independently tunable synthesizers can be specified per 1U chassis allowing for the highest integrated channel density available in its class. With an average power dissipation of less than 20 Watts per channel, the HSX9000 Series is highly efficient.

PHASE COHERENT CHANNELS

Holzworth HSX Series synthesizers offer the performance benefits of a proprietary multi-loop architecture with a centralized reference distribution subsystem, which maintains a tight phase coherent relationship across all integrated channels.

THE ULTIMATE IN CHANNEL-TO CHANNEL STABILITY

Different from traditional PLL based synthesizers, Holzworth's proprietary multi-loop architecture creates precisely synthesized signals that exhibit both instantaneous and long term stability. Temperature variations between the channels remain the only contribution to drift. The thermally optimized, fan-less chassis was specifically developed for maintaining the lowest possible thermal gradients from channel-to-channel. Channel specific thermal monitoring is available for tracking the relative channel temperature of each loaded synthesizer module.

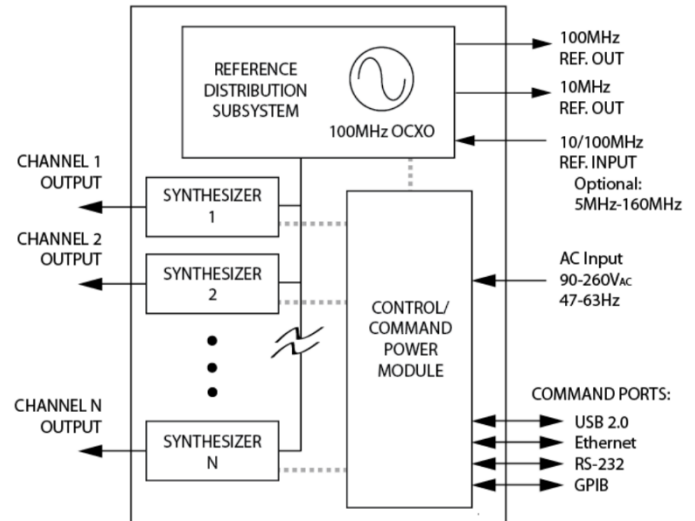



FREQUENCY PERFORMANCE ¹

The specified frequency performance parameters for the HSX Series RF Synthesizers are fully verified at final performance test and 100% guaranteed for the full warranty period of the product.

PARAMETER	MIN	TYPICAL	MAX	COMMENTS
Frequency Range PRELIMINARY / PREVIEW	10 MHz 10MHz 10MHz 10MHz 10MHz		3 GHz 6 GHz 12 GHz 24 GHz 40 GHz	See page 17 for channel selection options
Frequency Step Size		0.001 Hz		
Switching Speed (Frequency) SPI Mode (ASCII)			5ms	
Phase Offset Resolution		0.1 °		Base band 750-1500MHz (N=1) 0.05 ° ±0.05 °
Internal Time Base Reference (Oscillator Aging Rate)		± 1 ppm/yr		1 st year. ±0.5 ppm/yr each subsequent year
Temperature Effects		≤ ± 5 ppb		0 to 55 °C
Reference Output Frequency Amplitude Impedance	+4 dBm	100 MHz 50 Ω		Nominal Nominal
External Reference Input (standard) Input Frequency Lock Range External Amplitude Impedance Waveform	0 dBm	10/100MHz ± 4 ppm 50 Ω	+15 dBm	10MHz or Internal 100MHz Ref. 2Hz Locking BW 50 Ω (nom) Sine or Square
OPT-REFX Ext. Ref. Input (optional) Input Frequency Range Lock Range External Amplitude Impedance Waveform	5 MHz 0 dBm	± 4 ppm 50 Ω	160 MHz ± 1 ppm +10 dBm	Any 100kHz increment within range Sine or square

¹ Specifications are subject to change per the discretion of Holzworth Instrumentation, Inc

² All MIN/ MAX (Minimum/ Maximum) performance parameters are guaranteed and 100% verified during final performance test.

³ Typical performance is "by design" and consistent with field performance data.



3GHz AMPLITUDE PERFORMANCE ¹

This section contains performance specifications and data for channels that operate to 3GHz. The specified parameters for the HSX9000 Series RF Synthesizers are fully verified at final performance test and 100% guaranteed for the full warranty period of the product.

PARAMETER	MIN ²	TYPICAL ³	MAX ²	COMMENTS
Output Power (Calibrated) 10 MHz < f ≤ 3.0 GHz	-110 dBm		+18 dBm	Settable to +25dBm Refer to data on page 4
Maximum Output Power (unleveled) 10 MHz < f ≤ 3.0 GHz		+21 dBm		
Resolution		0.01 dB		
Connector		50 Ω		SMA (Jack)
Switching Speed (Amplitude)			5 ms	
Absolute Level Accuracy 10 MHz < f ≤ 3.0 GHz	+20 to -60 dBm -60 to -110 dBm	± 0.7 dB ± 1.0 dB		25C to 35C case temperature
SSB Phase Noise 10 MHz, 10 kHz offset 100 MHz, 10 kHz offset 375 MHz < f ≤ 750 MHz, 10kHz offset 750 MHz < f ≤ 1.5 GHz, 10kHz offset 1.5 GHz < f ≤ 3.0 GHz, 10kHz offset		≤ -165 dBc/Hz ≤ -157 dBc/Hz ≤ -148 dBc/Hz ≤ -142 dBc/Hz ≤ -136 dBc/Hz	≤ -159 dBc/Hz ≤ -151 dBc/Hz ≤ -142 dBc/Hz ≤ -136 dBc/Hz ≤ -130 dBc/Hz	Refer to Phase Noise performance plots on page 4
Harmonics (2nd / 3rd) 10 MHz < f ≤ 1.5 GHz 1.5 GHz < f ≤ 3.0 GHz		-35 dBc -25 dBc	-20 dBc -20 dBc	(Output set to +10dBm) Refer to Harmonics performance plots on page 5
Sub-Harmonics 10 MHz < f ≤ 1.5 GHz 1.5 GHz < f ≤ 3.0 GHz		N/A -70 dBc	Noise Floor -60 dBc	(Output set to +10dBm) Refer to Spurious performance plots on page 5
Non-Harmonics / Spurious 10 MHz < f ≤ 1.5 GHz 1.5 GHz < f ≤ 3.0 GHz		-85 dBc -80 dBc	-75 dBc -75 dBc	(Output set to 0dBm) Refer to Spurious performance plots on page 5

¹ Specifications are subject to change per the discretion of Holzworth Instrumentation, Inc.

² All MIN/ MAX (Minimum/ Maximum) performance parameters are guaranteed and 100% verified during final performance test.

³ Typical performance is "by design" and consistent with field performance data.



3GHz OUTPUT POWER – CALIBRATED (HIGH)

The plot in this section contains calibrated data from +18dBm to -12dBm.

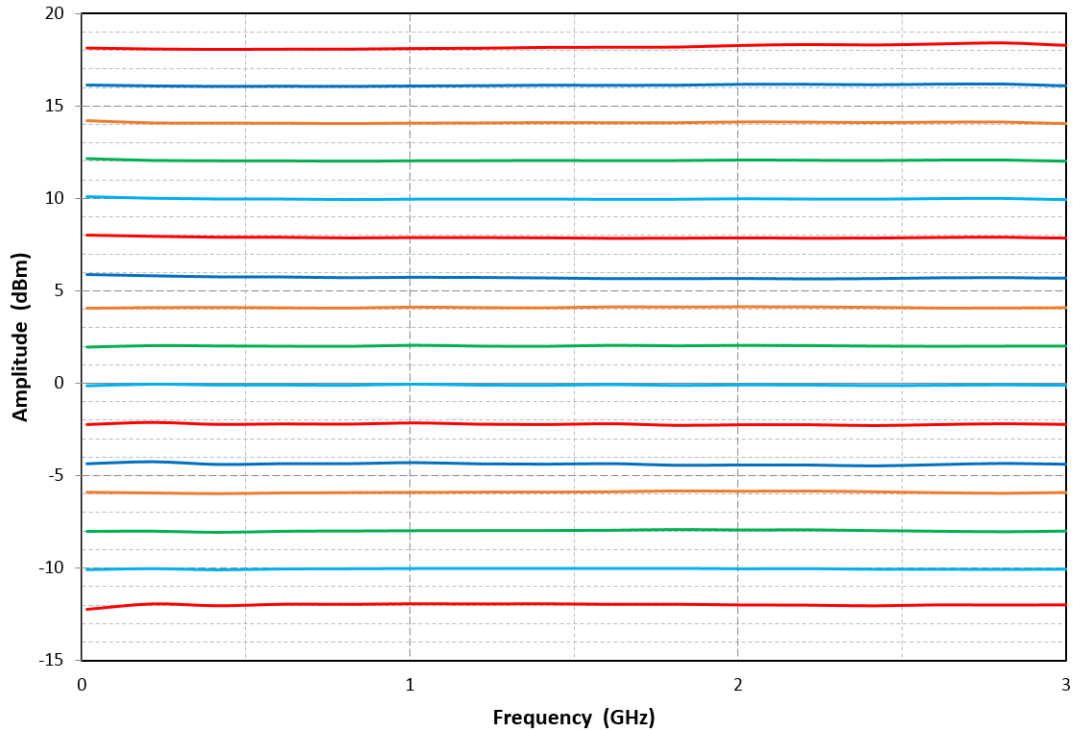

3GHz PHASE NOISE PERFORMANCE

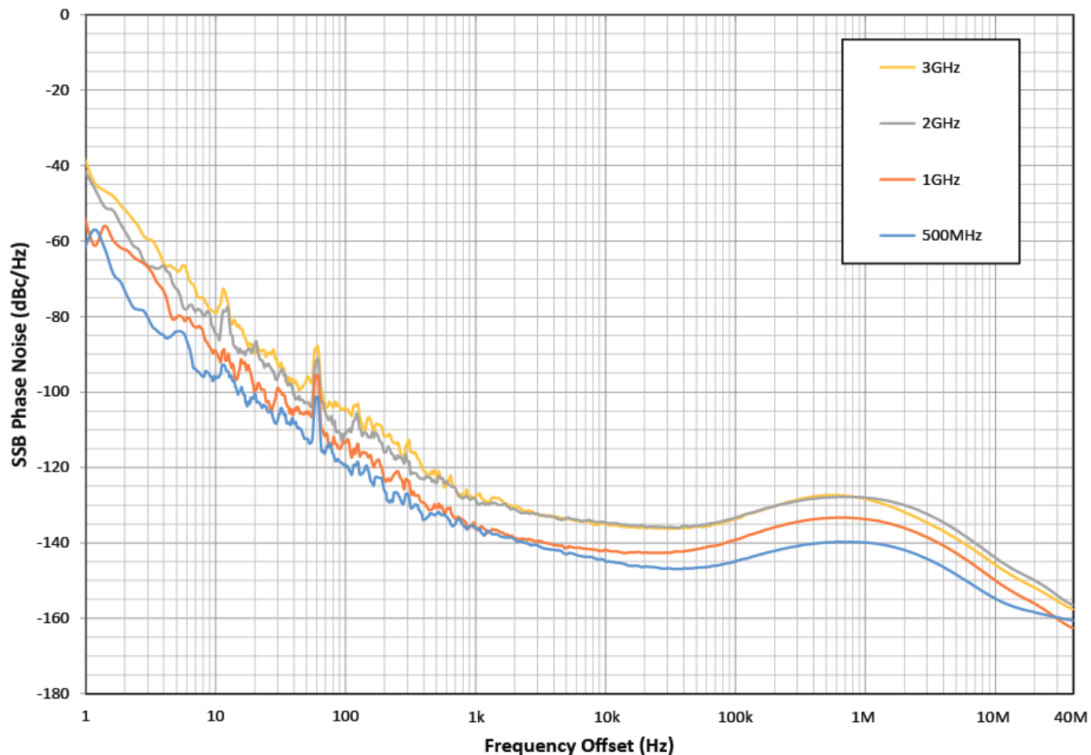



3GHz HARMONICS / SUB-HARMONICS

Harmonic and sub-harmonic data taken at +10dBm carrier power level.

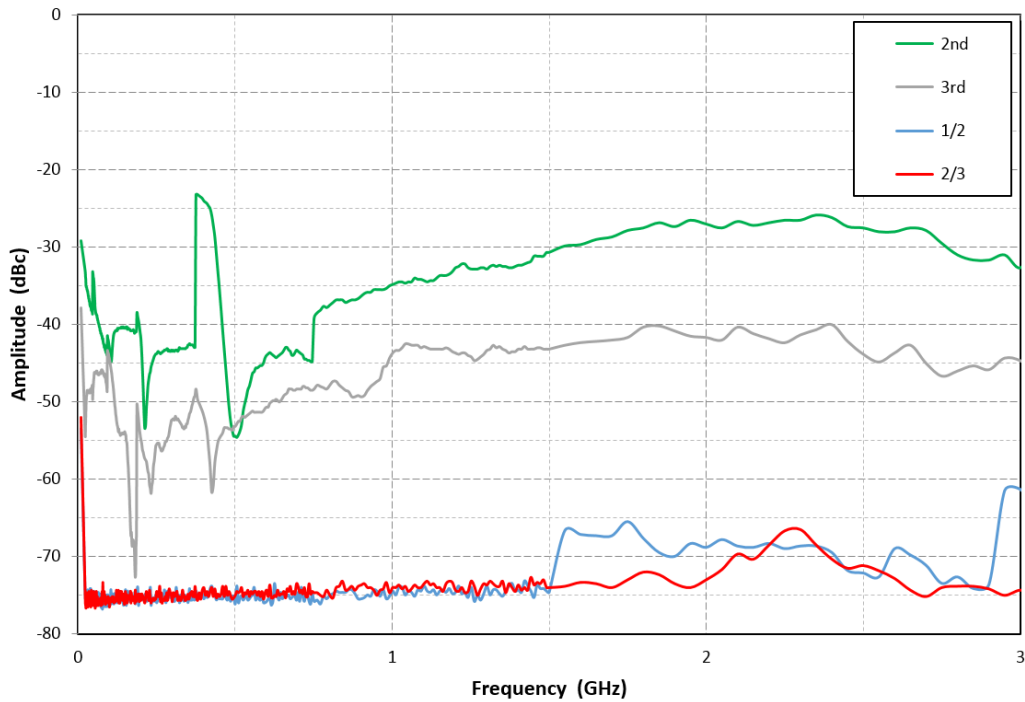

3GHz NON-HARMONIC / SPURIOUS

Spurious data taken at 0dBm carrier power level.

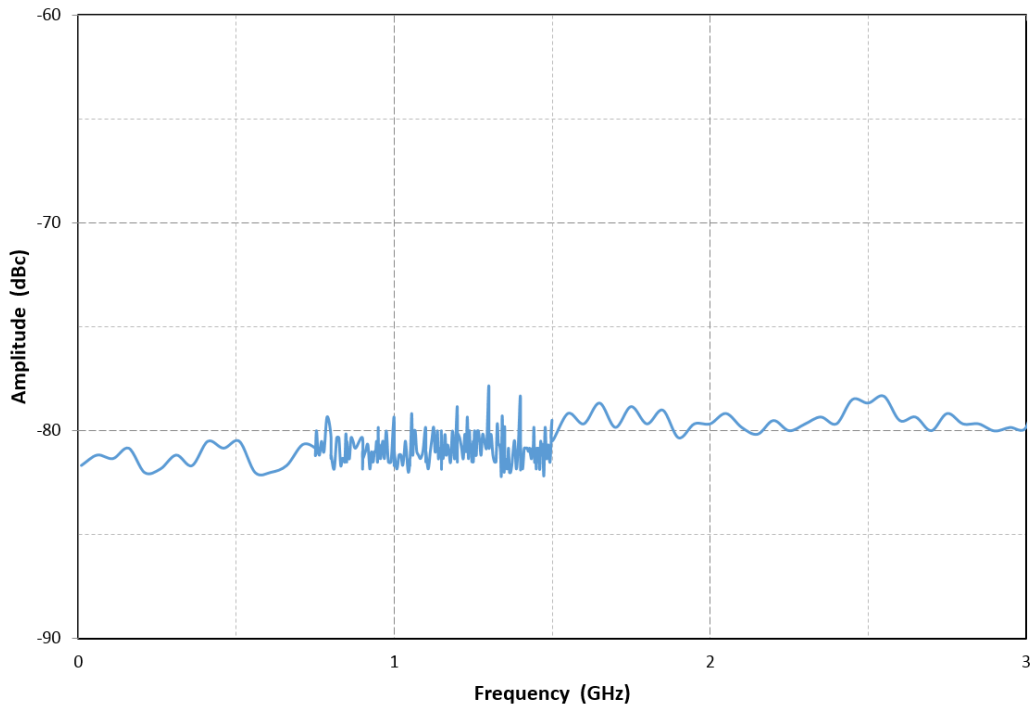

6GHz AMPLITUDE PERFORMANCE ¹

This section contains performance specifications and data for channels that operate to 6GHz. The specified parameters for the HSX9000 Series RF Synthesizers are fully verified at final performance test and 100% guaranteed for the full warranty period of the product.

PARAMETER	MIN ²	TYPICAL ³	MAX ²	COMMENTS
Output Power (Calibrated) 10 MHz < f ≤ 3.0 GHz 10 MHz < f ≤ 6.0 GHz	-110 dBm -110 dBm		+18 dBm +18 dBm	Settable to +25dBm Refer to data on page 7
Maximum Output Power (unleveled) 10 MHz < f ≤ 3.0 GHz 10 MHz < f ≤ 6.0 GHz		+21 dBm +21 dBm		
Resolution		0.01 dB		
Connector		50 Ω		SMA (Jack)
Switching Speed (Amplitude)			5 ms	
Absolute Level Accuracy 10 MHz < f ≤ 3.0 GHz 3.0 GHz < f ≤ 6.0 GHz	+20 to -60 dBm -60 to -110 dBm +20 to -60 dBm -60 to -110 dBm	± 0.7 dB ± 1.0 dB ± 0.7 dB ± 1.3 dB		25C to 35C case temperature
SSB Phase Noise 10 MHz, 10 kHz offset 100 MHz, 10 kHz offset 375 MHz < f ≤ 750 MHz, 10kHz offset 750 MHz < f ≤ 1.5 GHz, 10kHz offset 1.5 GHz < f ≤ 3.0 GHz, 10kHz offset 3.0 GHz < f ≤ 6.0 GHz, 10kHz offset		≤ -165 dBc/Hz ≤ -157 dBc/Hz ≤ -148 dBc/Hz ≤ -142 dBc/Hz ≤ -136 dBc/Hz ≤ -130 dBc/Hz	≤ -159 dBc/Hz ≤ -151 dBc/Hz ≤ -142 dBc/Hz ≤ -136 dBc/Hz ≤ -130 dBc/Hz ≤ -124 dBc/Hz	Refer to Phase Noise performance plots on page 7
Harmonics (2nd / 3rd) 10 MHz < f ≤ 1.5 GHz 1.5 GHz < f ≤ 3.0 GHz 3.0 GHz < f ≤ 6.0 GHz		-35 dBc -25 dBc -30 dBc	-20 dBc -20 dBc -25 dBc	(Output set to +10dBm) Refer to Harmonics performance plots on page 8
Sub-Harmonics 10 MHz < f ≤ 1.5 GHz 1.5 GHz < f ≤ 3.0 GHz 3.0 GHz < f ≤ 6.0 GHz		N/A -70 dBc -65 dBc	Noise Floor -60 dBc -50 dBc	(Output set to +10dBm) Refer to Spurious performance plots on page 8
Non-Harmonics / Spurious 10 MHz < f ≤ 1.5 GHz 1.5 GHz < f ≤ 3.0 GHz 3.0 GHz < f ≤ 6.0 GHz		-85 dBc -80 dBc -76 dBc	-75 dBc -75 dBc -70 dBc	(Output set to 0dBm) Refer to Spurious performance plots on page 8

¹ Specifications are subject to change per the discretion of Holzworth Instrumentation, Inc.

² All MIN/ MAX (Minimum/ Maximum) performance parameters are guaranteed and 100% verified during final performance test.

³ Typical performance is "by design" and consistent with field performance data.

6GHz OUTPUT POWER – CALIBRATED (HIGH)

The plot in this section contains calibrated data from +18dBm to -12dBm.

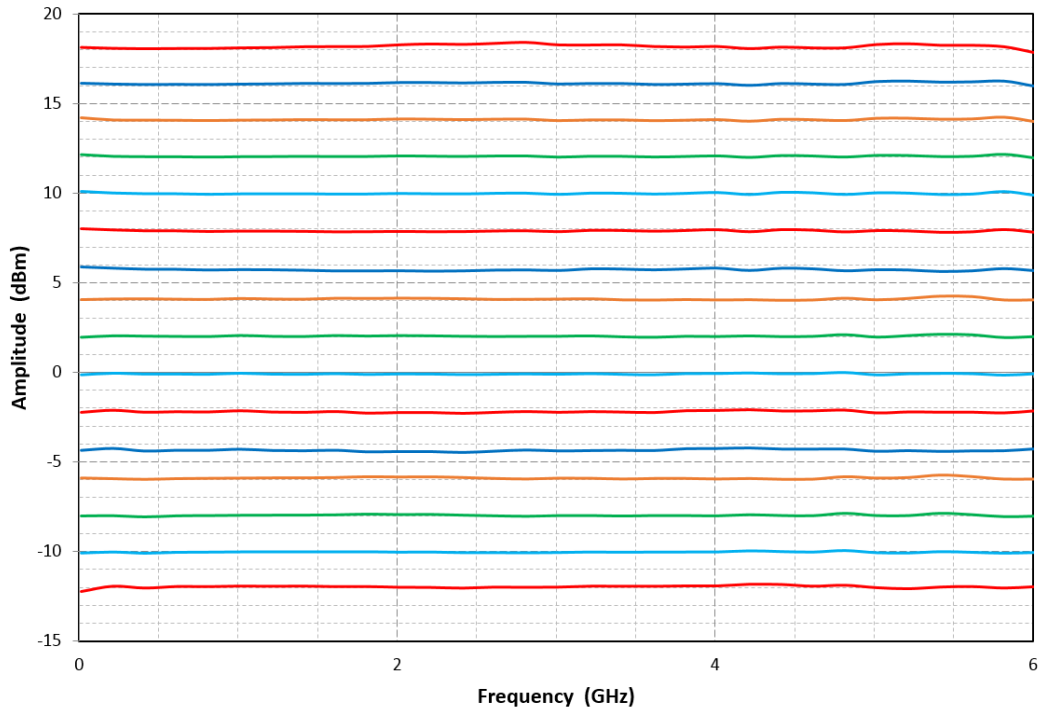

6GHz PHASE NOISE PERFORMANCE

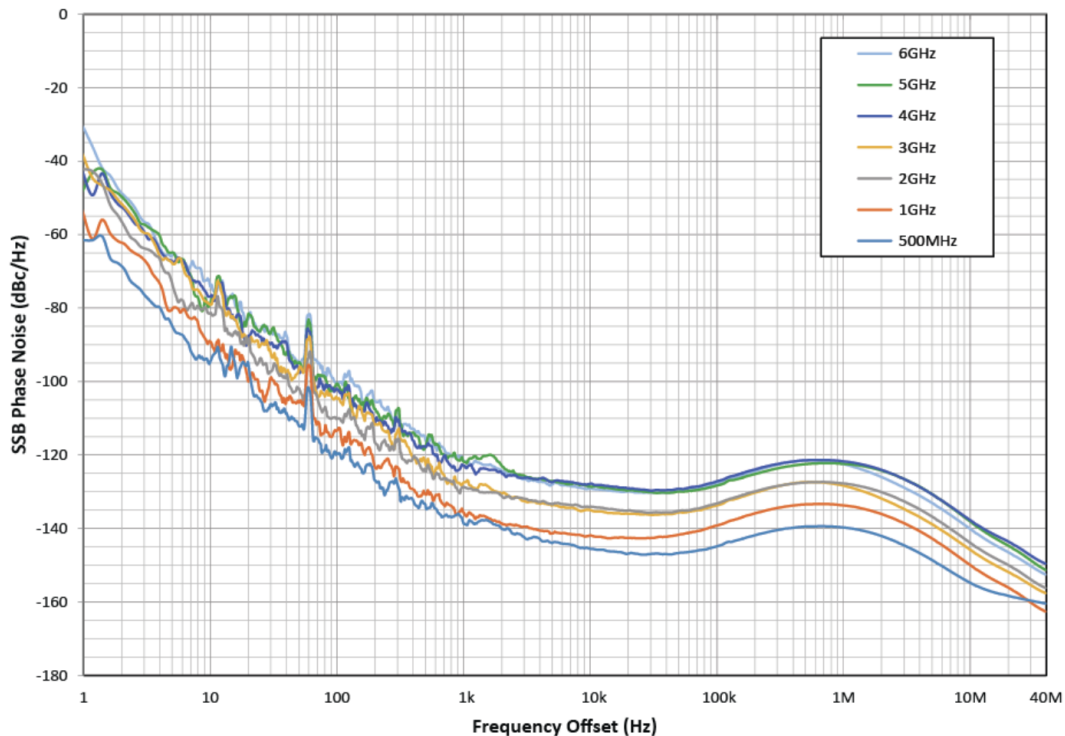



6GHz HARMONICS / SUB-HARMONICS

Harmonic and sub-harmonic data taken at +10dBm carrier power level.

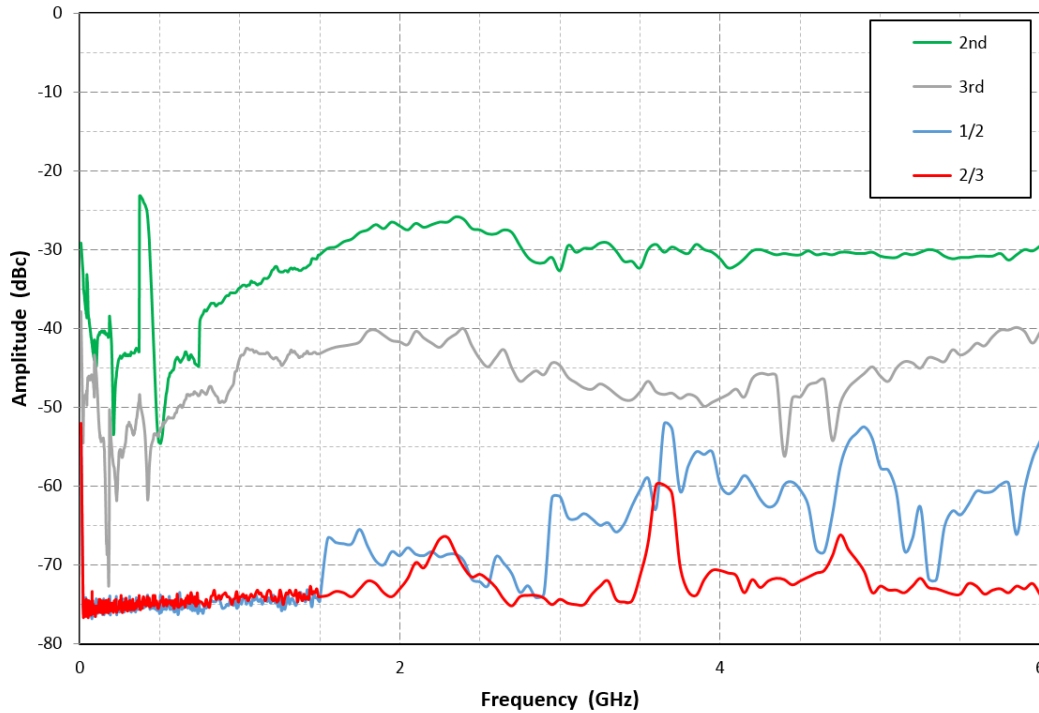

6GHz NON-HARMONIC / SPURIOUS

Spurious data taken at 0dBm carrier power level.

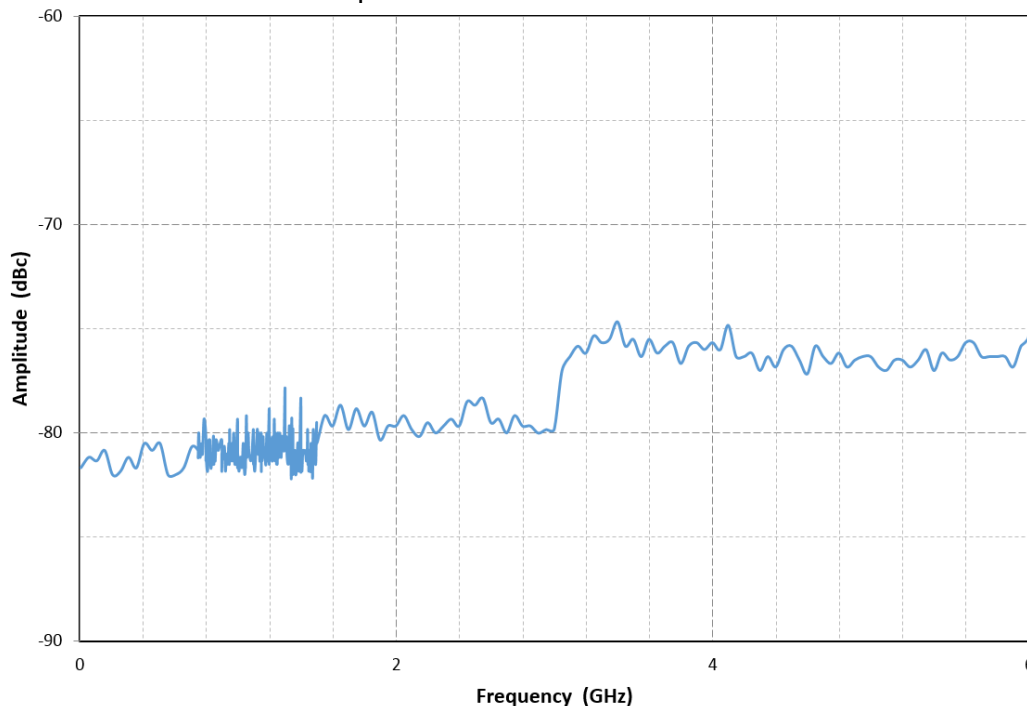

12GHz AMPLITUDE PERFORMANCE ¹

This section contains performance specifications and data for channels that operate to 12GHz. The specified parameters for the HSX9000 Series RF Synthesizers are fully verified at final performance test and 100% guaranteed for the full warranty period of the product.

PARAMETER	MIN ²	TYPICAL ³	MAX ²	COMMENTS
Output Power (Calibrated) 10 MHz < f ≤ 12.0 GHz	-60 dBm		+20 dBm	Settable from -70 to +25 dBm
Maximum Output Power (unleveled) 10 MHz < f ≤ 6.0 GHz 6.0GHz < f ≤ 12.0GHz		+25 dBm +23 dBm		Refer to data on page 10
Resolution		0.01 dB		
Connector		50 Ω		SMA (Jack)
Switching Speed (Amplitude)			5 ms	
Absolute Level Accuracy 10 MHz < f ≤ 6.0 GHz 6.0 GHz < f ≤ 12.0 GHz	+20 to -10 dBm -10 to -60 dBm -60 to -90 dBm +18 to -10 dBm -10 to -60 dBm	± 0.7 dB ± 1.0 dB ± 1.4 dB ± 0.9 dB ± 1.4 dB		25C to 35C case temperature
SSB Phase Noise 10 MHz, 10 kHz offset 100 MHz, 10 kHz offset 375 MHz < f ≤ 750 MHz, 10kHz offset 750 MHz < f ≤ 1.5 GHz, 10kHz offset 1.5 GHz < f ≤ 3.0 GHz, 10kHz offset 3.0 GHz < f ≤ 6.0 GHz, 10kHz offset 6.0 GHz < f ≤ 12.0 GHz, 10kHz offset		≤ -165 dBc/Hz ≤ -157 dBc/Hz ≤ -148 dBc/Hz ≤ -142 dBc/Hz ≤ -136 dBc/Hz ≤ -130 dBc/Hz ≤ -124 dBc/Hz	≤ -159 dBc/Hz ≤ -151 dBc/Hz ≤ -142 dBc/Hz ≤ -136 dBc/Hz ≤ -130 dBc/Hz ≤ -124 dBc/Hz ≤ -118 dBc/Hz	Refer to Phase Noise performance plots on page 10
Harmonics (2nd/3rd) 10 MHz < f ≤ 1.5 GHz 1.5 GHz < f ≤ 6.0 GHz 6.0 GHz < f ≤ 12.0 GHz		-40/-40 dBc -22/-30 dBc -27/-37 dBc	-20 dBc -20 dBc -20 dBc	(Output set to +10dBm) Refer to Harmonics performance plots on page 11
Sub-Harmonics 10 MHz < f ≤ 1.5 GHz 1.5 GHz < f ≤ 12.0 GHz		N/A <-60 dBc	Noise Floor -50 dBc	(Output set to +10dBm) Refer to Spurious performance plots on page 11
Non-Harmonics / Spurious 10 MHz < f ≤ 1.5 GHz 1.5 GHz < f ≤ 3.0 GHz 3.0 GHz < f ≤ 6.0 GHz 6.0 GHz < f ≤ 12.0 GHz		-85 dBc -80 dBc -76 dBc -72 dBc	-75 dBc -75 dBc -70 dBc -65 dBc	(Output set to 0dBm) Refer to Spurious performance plots on page 11

¹ Specifications are subject to change per the discretion of Holzworth Instrumentation, Inc.

² All MIN/ MAX (Minimum/ Maximum) performance parameters are guaranteed and 100% verified during final performance test.

³ Typical performance is "by design" and consistent with field performance data.

12GHz MAXIMUM OUTPUT POWER

The data shown here represents typical unleveled performance.

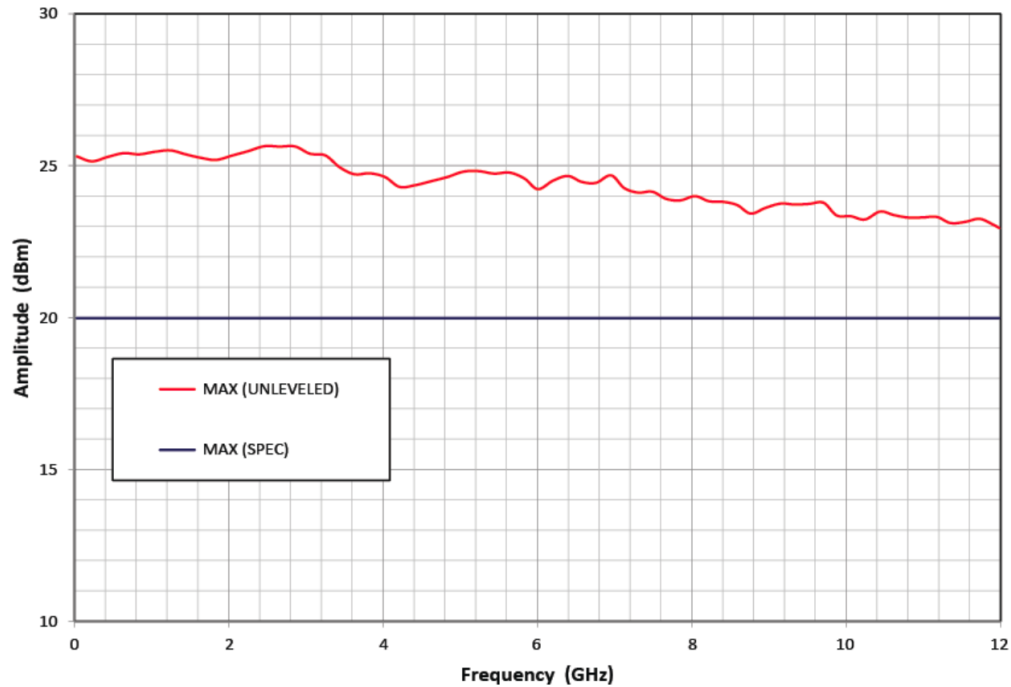

12GHz PHASE NOISE PERFORMANCE

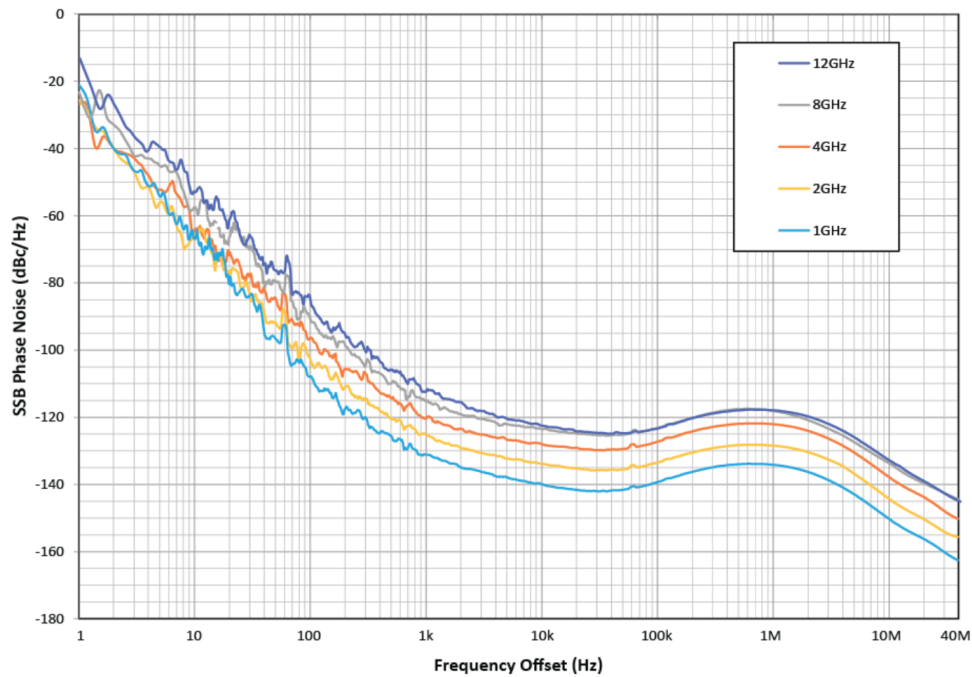



12GHz HARMONICS / SUB-HARMONICS

Harmonic and sub-harmonic data taken at +10dBm carrier power level.

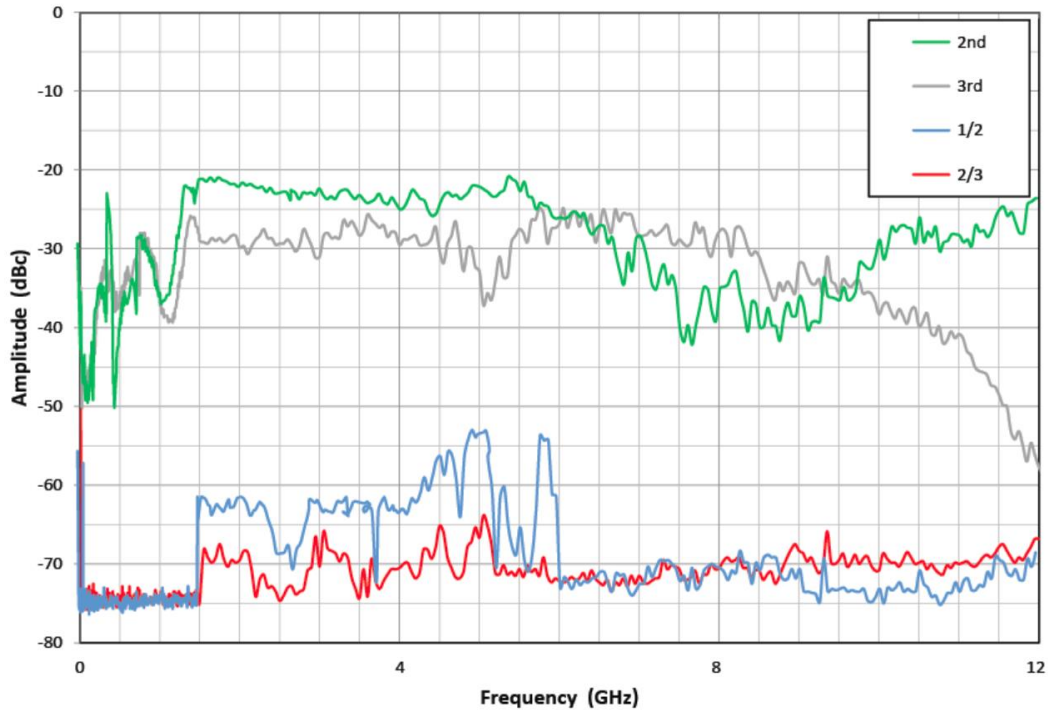

12GHz NON-HARMONIC / SPURIOUS

Spurious data taken at 0dBm carrier power level.

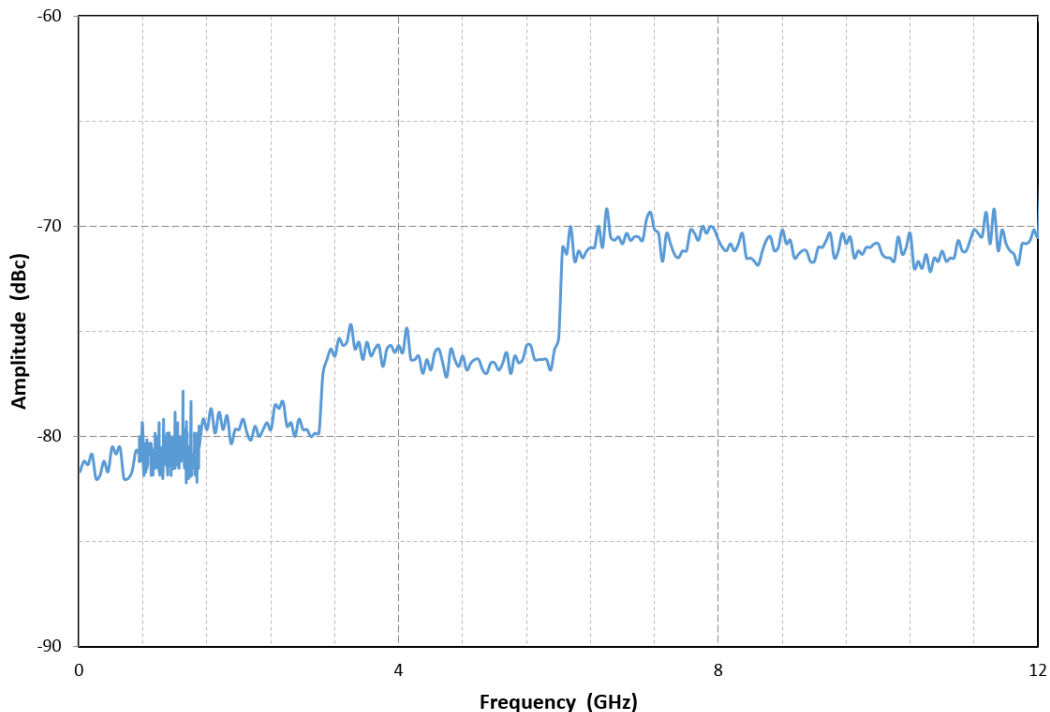

24GHz AMPLITUDE PERFORMANCE ¹

This section contains performance specifications and data for channels that operate to 24GHz. The specified parameters for the HSX9000 Series RF Synthesizers are fully verified at final performance test and 100% guaranteed for the full warranty period of the product.

PARAMETER	MIN ²	TYPICAL ³	MAX ²	COMMENTS
Output Power (Calibrated) 10 MHz < f ≤ 12.0 GHz 12.0 GHz < f ≤ 24.0 GHz	-60 dBm -60 dBm		+20 dBm +18 dBm	Settable from -70dBm to +25dBm
Maximum Output Power (unleveled) 10 MHz < f ≤ 6.0 GHz 6.0GHz < f ≤ 12.0GHz 12.0GHz < f ≤ 24.0GHz		+25 dBm +23 dBm +20 dBm		Refer to data on page 13
Resolution		0.01 dB		
Connector		50 Ω		SSMA (Jack)
Switching Speed (Amplitude)			5 ms	
Absolute Level Accuracy 10 MHz < f ≤ 6.0 GHz 6.0 GHz < f ≤ 24.0 GHz	+20 to -10 dBm -10 to -60 dBm -60 to -90 dBm +18 to -10 dBm -10 to -60 dBm	± 0.7 dB ± 1.0 dB ± 1.4 dB ± 0.9 dB ± 1.4 dB		25C to 35C case temperature
SSB Phase Noise 10 MHz, 10 kHz offset 100 MHz, 10 kHz offset 375 MHz < f ≤ 750 MHz, 10kHz offset 750 MHz < f ≤ 1.5 GHz, 10kHz offset 1.5 GHz < f ≤ 3.0 GHz, 10kHz offset 3.0 GHz < f ≤ 6.0 GHz, 10kHz offset 6.0 GHz < f ≤ 12.0 GHz, 10kHz offset 12.0 GHz < f ≤ 24.0 GHz, 10kHz offset		≤ -165 dBc/Hz ≤ -157 dBc/Hz ≤ -148 dBc/Hz ≤ -142 dBc/Hz ≤ -136 dBc/Hz ≤ -130 dBc/Hz ≤ -124 dBc/Hz ≤ -118 dBc/Hz	≤ -159 dBc/Hz ≤ -151 dBc/Hz ≤ -142 dBc/Hz ≤ -136 dBc/Hz ≤ -130 dBc/Hz ≤ -124 dBc/Hz ≤ -118 dBc/Hz	Refer to Phase Noise performance plots on page 13
Harmonics (2nd/3rd) 10 MHz < f ≤ 1.5 GHz 1.5 GHz < f ≤ 6.0 GHz 6.0 GHz < f ≤ 12.0 GHz 12.0 GHz < f ≤ 24.0 GHz		-40/-40 dBc -22/-30 dBc -27/-37 dBc -25/-60 dBc	-20 dBc -20 dBc -20 dBc -20 dBc	(Output set to +10dBm) Refer to Harmonics performance plots on page 14
Sub-Harmonics 10 MHz < f ≤ 1.5 GHz 1.5 GHz < f ≤ 24.0 GHz		N/A <-60 dBc	Noise Floor -50 dBc	(Output set to +10dBm) Refer to Spurious performance plots on page 14
Non-Harmonics / Spurious 10 MHz < f ≤ 1.5 GHz 1.5 GHz < f ≤ 3.0 GHz 3.0 GHz < f ≤ 6.0 GHz 6.0 GHz < f ≤ 12.0 GHz 12.0 GHz < f ≤ 24.0 GHz		-85 dBc -80 dBc -76 dBc -72 dBc -65 dBc	-75 dBc -75 dBc -70 dBc -65 dBc -60 dBc	(Output set to 0dBm) Refer to Spurious performance plots on page 14

¹ Specifications are subject to change per the discretion of Holzworth Instrumentation, Inc.

² All MIN/ MAX (Minimum/ Maximum) performance parameters are guaranteed and 100% verified during final performance test.

³ Typical performance is "by design" and consistent with field performance data.

24GHz MAXIMUM OUTPUT POWER

The data shown here represents typical unleveled performance.

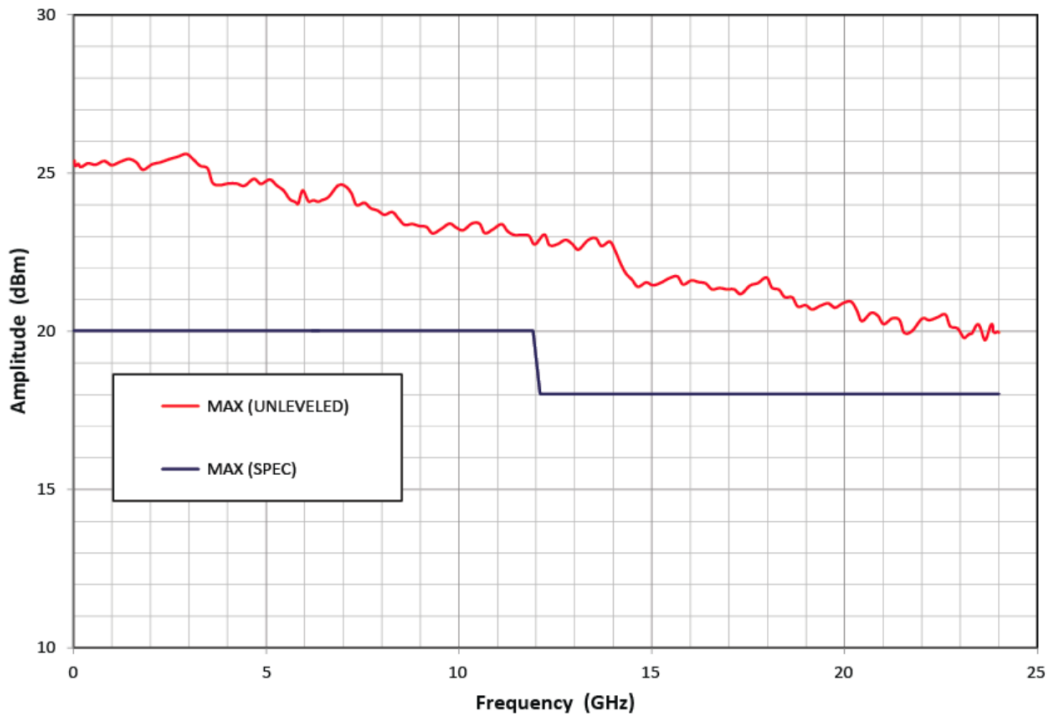

24GHz PHASE NOISE PERFORMANCE

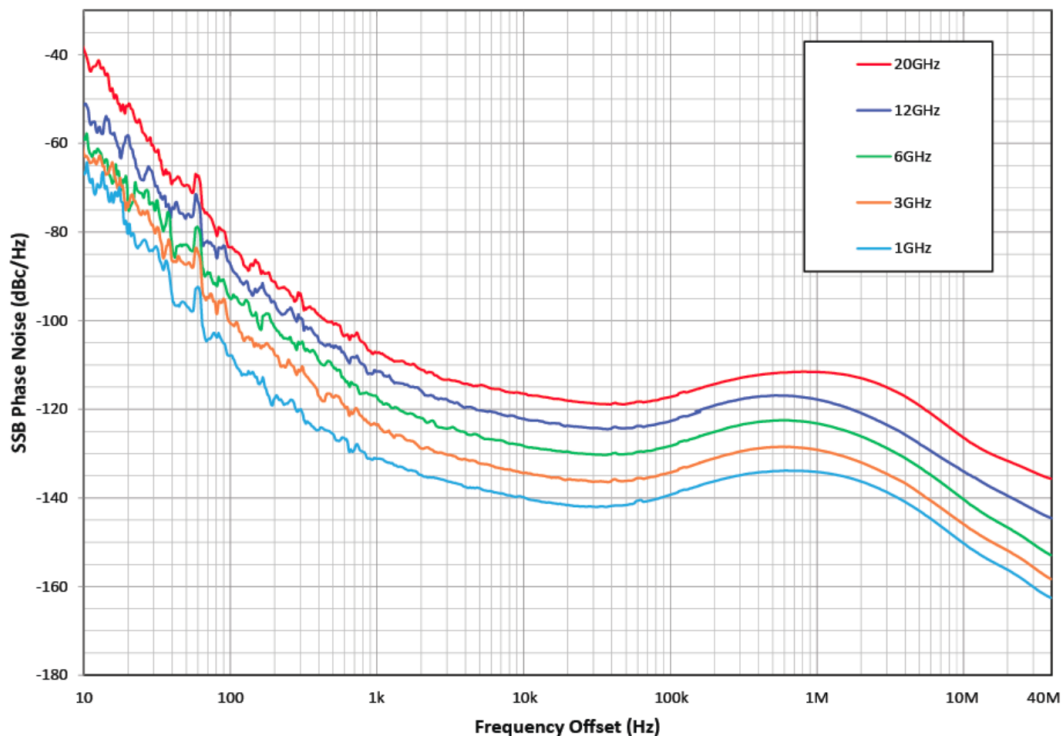

24GHz HARMONICS / SUB-HARMONICS

Harmonic and sub-harmonic data taken at +10dBm carrier power level.

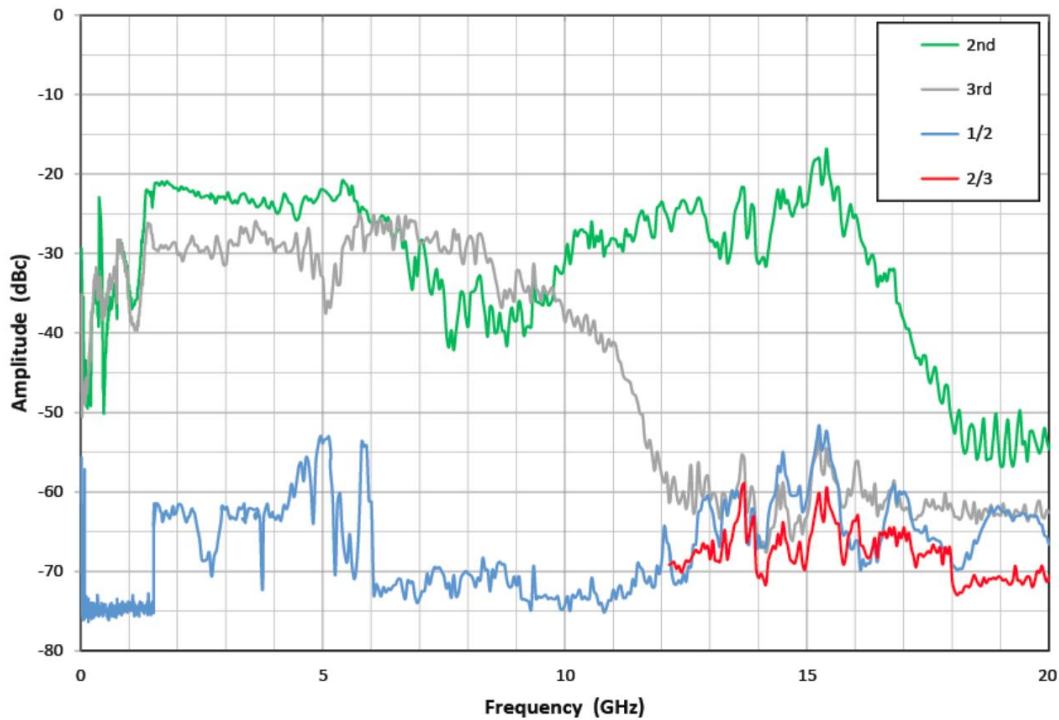
**24GHz NON-HARMONIC / SPURIOUS**

Spurious data taken at 0dBm carrier power level.

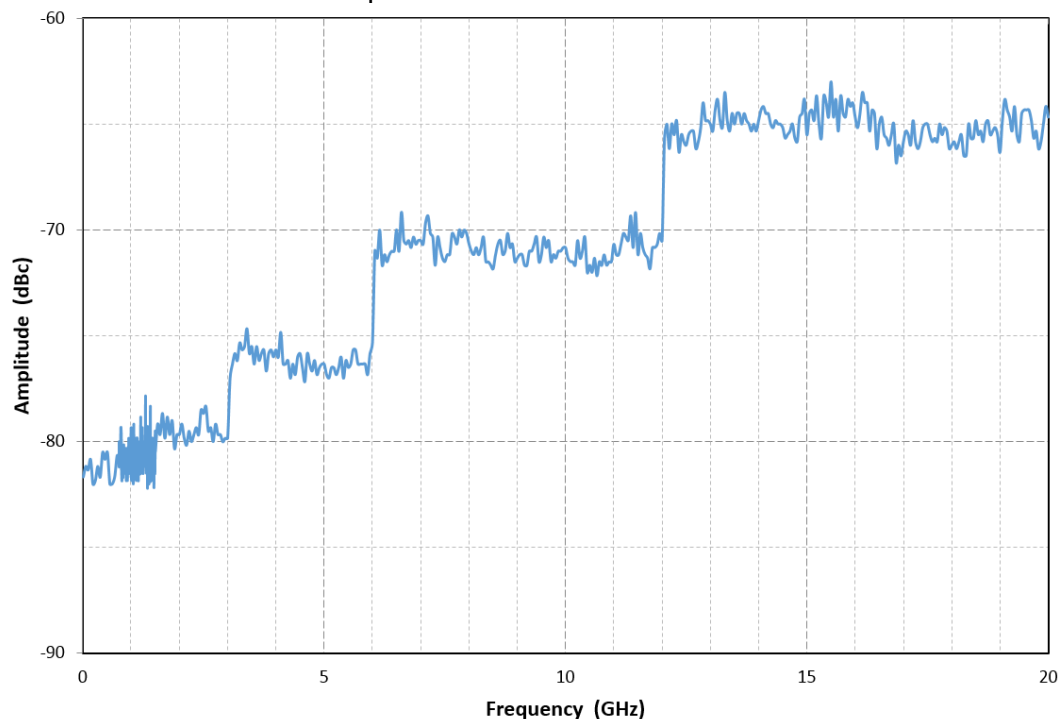

40GHz AMPLITUDE PERFORMANCE ¹ PRELIMINARY

This section contains preliminary performance specifications for channels that operate to 40GHz. The specified parameters for the HSX9000 Series RF Synthesizers are fully verified at final performance test and 100% guaranteed for the full warranty period of the product.

PARAMETER	MIN ²	TYPICAL ³	MAX ²	COMMENTS
Output Power (Calibrated) 10 MHz < f ≤ 6.0 GHz 6.0 GHz < f ≤ 12.0 GHz 12.0 GHz < f ≤ 24.0 GHz 24.0 GHz < f ≤ 40.0 GHz	-60 dBm -60 dBm -60 dBm -60 dBm		+20 dBm +18 dBm +16 dBm +12 dBm	Settable from -70dBm to +25dBm
Maximum Output Power (unleveled) 10 MHz < f ≤ 6.0 GHz 6.0GHz < f ≤ 12.0GHz 12.0GHz < f ≤ 24.0GHz 24.0 GHz < f ≤ 40.0 GHz		+21 dBm +20 dBm +18 dBm +15 dBm		
Resolution		0.01 dB		
Connector		50 Ω		2.92mm (Jack)
Switching Speed (Amplitude)			5 ms	
Absolute Level Accuracy 10 MHz < f ≤ 6.0 GHz 6.0 GHz < f ≤ 24.0 GHz 24.0 GHz < f ≤ 40.0 GHz	+20 to -10 dBm -10 to -60 dBm +18 to -10 dBm -10 to -60 dBm +18 to -10 dBm -10 to -60 dBm	± 0.7 dB ± 1.0 dB ± 1.4 dB ± 0.9 dB ± 1.4 dB TBD TBD		25C to 35C case temperature
SSB Phase Noise (10kHz offset) 10 MHz 100 MHz 375 MHz < f ≤ 750 MHz 750 MHz < f ≤ 1.5 GHz 1.5 GHz < f ≤ 3.0 GHz 3.0 GHz < f ≤ 6.0 GHz 6.0 GHz < f ≤ 12.0 GHz 12.0 GHz < f ≤ 24.0 GHz 24.0 GHz < f ≤ 40.0 GHz		≤ -165 dBc/Hz ≤ -157 dBc/Hz ≤ -148 dBc/Hz ≤ -142 dBc/Hz ≤ -136 dBc/Hz ≤ -130 dBc/Hz ≤ -124 dBc/Hz ≤ -118 dBc/Hz ≤ -112 dBc/Hz	≤ -159 dBc/Hz ≤ -151 dBc/Hz ≤ -142 dBc/Hz ≤ -136 dBc/Hz ≤ -130 dBc/Hz ≤ -124 dBc/Hz ≤ -118 dBc/Hz ≤ -112 dBc/Hz ≤ -106 dBc/Hz	
Harmonics (2nd/3rd) 10 MHz < f ≤ 1.5 GHz 1.5 GHz < f ≤ 3.0 GHz 3.0 GHz < f ≤ 6.0 GHz 6.0 GHz < f ≤ 24.0 GHz 24.0 GHz < f ≤ 40.0 GHz		-40/-40 dBc -22/-30 dBc -27/-37 dBc -25/-60 dBc TBD	-20 dBc -20 dBc -20 dBc -20 dBc TBD	
Sub-Harmonics 10 MHz < f ≤ 1.5 GHz 1.5 GHz < f ≤ 24.0 GHz 24.0 GHz < f ≤ 40.0 GHz		N/A <-60 dBc <-60 dBc	Noise Floor -50 dBc -50 dBc	
Non-Harmonics / Spurious 10 MHz < f ≤ 1.5 GHz 1.5 GHz < f ≤ 3.0 GHz 3.0 GHz < f ≤ 6.0 GHz 6.0 GHz < f ≤ 12.0 GHz 12.0 GHz < f ≤ 24.0 GHz 24.0 GHz < f ≤ 40.0 GHz		-85 dBc -80 dBc -76 dBc -72 dBc -65 dBc -58 dBc	-75 dBc -75 dBc -70 dBc -65 dBc -60 dBc -50 dBc	

¹ Specifications are subject to change per the discretion of Holzworth Instrumentation, Inc.

² All MIN/ MAX (Minimum/ Maximum) performance parameters are guaranteed and 100% verified during final performance test.

³ Typical performance is "by design" and consistent with field performance data.



ENVIRONMENTAL SPECIFICATIONS¹

Environmental specifications are based on component margins, thermal verification testing and current draw tests. Production unit performance is not verified over temperature.

PARAMETER	MIN	TYPICAL	MAX	COMMENTS
Operating Temperature	0 C		+55 C	
Temperature Monitor Range	-40 C		+85 C	Absolute, channel dedicated outputs
AC Power Supply	90 V _{AC}		260 V _{AC}	47 – 63Hz
Power Consumption Chassis Channel (per)		5 W 17 W		HSX9003 (3 channel) Example: 5W + (17W * 3) = 56W Total
Warm-Up Time		10 min	20 min	20 C (ambient temp. dependent)

¹ Specifications are subject to change per the discretion of Holzworth Instrumentation, Inc

DESCRIPTION	SPECIFICATION (by design)
Operating Environment Humidity Altitude Vibration	RH 20% to 80% at wet bulb temp. <29C (non-condensing) 0 to 2,000m (0 to 6,561 feet) 0.21 G-rms maximum, 5Hz to 500Hz
Storage (Non-Operating) Temperature Humidity Altitude Altitude Vibration	-10C to + 60C RH 20% to 80% at wet bulb temp. <40C (non-condensing) 0 to 4,572m (0 to 15,000 feet) 0.5 G-rms maximum, 5Hz to 500Hz

HSX9000 SERIES CONFIGURATION GUIDE

The HSX9000 Series synthesizer platform is designed to be user/application defined. Follow 4 easy steps to determine the part number with the required options.

STEP 1: SELECT TOTAL NUMBER OF CHANNELS

Select the base part number, strictly calling out the total number of channels to be loaded into the multi-channel chassis.

No. Channels	1	2	3	4
Part Number	HSX9001A	HSX9002A	HSX9003A	HSX9004A

STEP 2: SELECT CHANNEL FREQUENCY OPTIONS

Select any combination of channel frequency options. Note that the total number of channels specified here must equal the number of channels selected under STEP 1.

Frequency Range	Number of Channels per Frequency Range			
	1x	2x	3x	4x
10MHz – 3GHz	OPT-103	OPT-203	OPT-303	OPT-403
10MHz – 6GHz	OPT-106	OPT-206	OPT-306	OPT-406
10MHz – 12GHz	OPT-112	OPT-212	OPT-312	OPT-412
10MHz – 24GHz	OPT-120	OPT-220	OPT-320	OPT-420
10MHz – 40GHz	OPT-140	OPT-240	N/A	N/A

PRE-RELEASE INFORMATION

STEP 3: SELECT ADDITIONAL OPTIONS & ACCESSORIES

The options listed in this section are available for the multi-channel platform to comply with application specific requirements.

TYPE	Part Number	Description
OPTION	OPT-REFX	5MHz – 160MHz Reference Input Frequency Range (degraded phase noise)
ACCESSORY	RACK-1U	19" Rack Mount Bracket Kit, 90° rear bracket
ACCESSORY	RACK2-1U	19" Rack Mount Bracket Kit, straight rear bracket

PART NUMBER EXAMPLE

Ordering a 3 channel HSX synthesizer with 3x 10MHz-6GHz channels would result in the following configuration:

Part Number: HSX9004A Options: OPT-106 OPT-212 OPT-120	Description: 4 channel HSX RF Synthesizer 1x 6GHz Channel 2x 12GHz Channels 1x 24GHz Channel
---	---

MECHANICAL CONFIGURATION

The HSX9000 Series comes in a 1U high, rack mountable chassis. The example shown is of a 4 channel unit (front panel configuration may vary). A universal rack mount bracket kit is an available accessory (Part No.: RACK-1U or RACK2-1U). Mechanical dimensions are listed in inches (and millimeters).

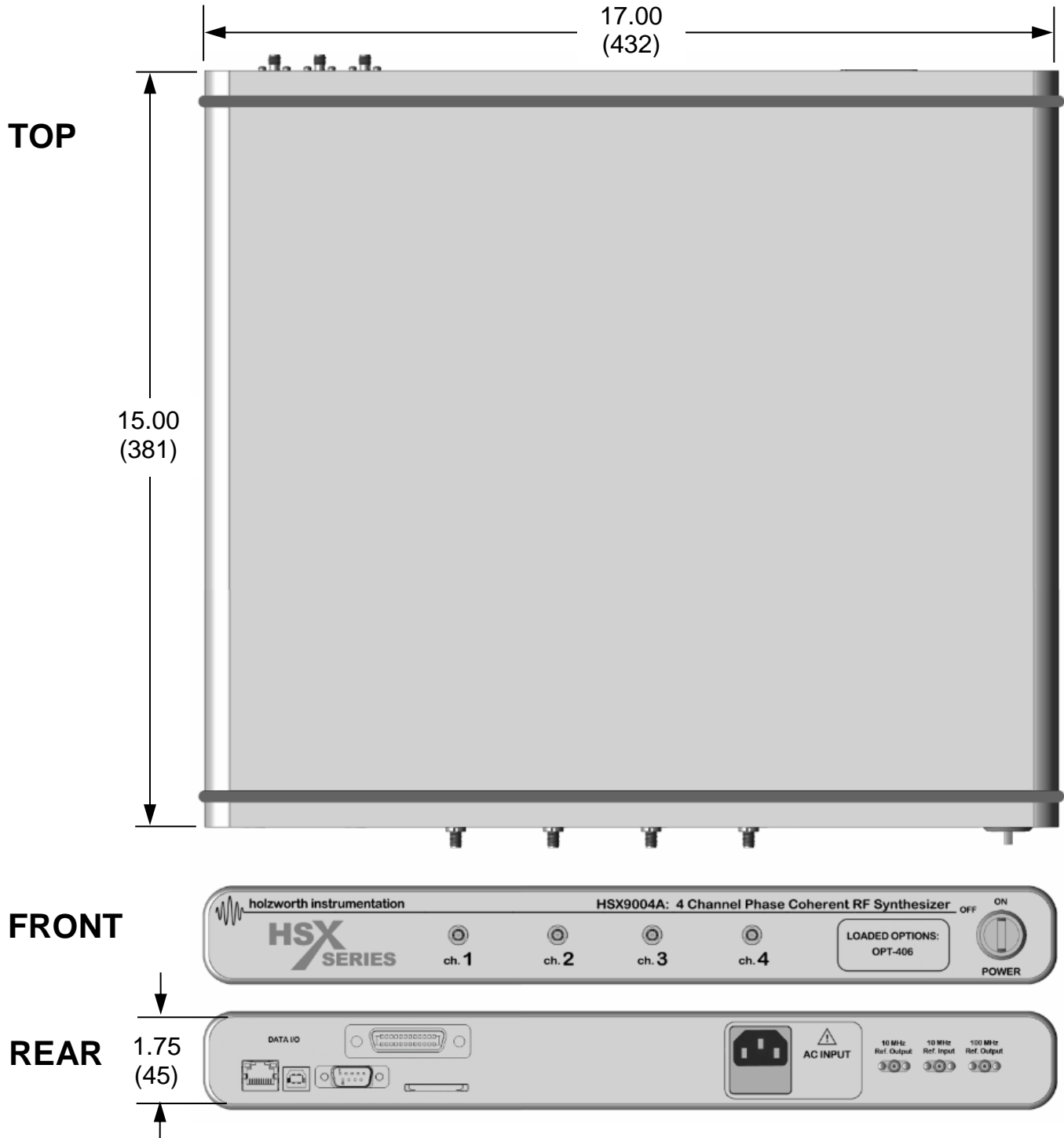



CONNECTORS and PHYSICAL SPECIFICATIONS

FRONT PANEL

DESCRIPTION	CONFIGURATION
RF Output(s) Connector Type	SMA-J, 50ohm: OPT-n03, OPT-n06, OPT-n12 (n = number of channels = number of connectors) SSMA-J, 50ohm: OPT-n20 (n = number of channels = number of connectors) 2.92mm-J, 50ohm: OPT-n40 (n = number of channels = number of connectors)

REAR PANEL

DESCRIPTION	CONFIGURATION
Reference Output Port Connector Type Output Frequency Output Level Output Waveform	SMA, 50ohm 10MHz \pm 10Hz and 100MHz \pm 10Hz +5dBm \pm 2dBm Sinusoid
Reference Input Port Connector Type Input Frequency Input Level	SMA, 50ohm 10MHz \pm 10Hz 0dBm to +15dBm (Sinusoid or Square)
AC Power Input Connector Type AC Input Rating	IEC 320-C13 90-260V _{AC} , 47-63Hz. Specify country at time of order for proper power cord.
Data I/O Interface Connectivity Storage	USB B-Type (virtual comm. port), Ethernet, RS-232, GPIB SD Card Reader

PHYSICAL

Dimensions (L x W x H)	1U high, 19" rack mount: 15in x 17in x 1.75in (381mm x 431.8mm x 44.5mm)
Weight	25 lb (11.34 kilograms) MAXIMUM



INCLUDED HARDWARE AND CERTIFICATIONS

Each product delivery includes specified hardware and certifications.

TYPE	DESCRIPTION	COMMENTS
HARDWARE	HSX9000 SERIES SYNTHESIZER	DELIVERABLE
HARDWARE	AC Power Cord (7ft/2.1m) ⁶	DELIVERABLE
HARDWARE	Ethernet Cable (10ft/3m)	DELIVERABLE
HARDWARE	USB Cable (6ft/1.8m)	DELIVERABLE
WARRANTY	3 YEAR MANUFACTURER'S WARRANTY	NON-DELIVERABLE
CERTIFICATE	CALIBRATION CERTIFICATION	DELIVERABLE
CERTIFICATE	CE COMPLIANCE CERTIFICATE <i>DIRECTIVE: 2004/108/EC, TEST STANDARD: EN 61326-1: 2006</i>	WEB DOWNLOAD
CERTIFICATE	RoHS COMPLIANCE CERTIFICATE <i>DIRECTIVE: 2002/95/EC</i>	WEB DOWNLOAD
CERTIFICATE	WEEE COMPLIANCE STATEMENT <i>DIRECTIVE: 2002/96/EC</i>	WEB DOWNLOAD

⁶ Specify final country of destination for shipment with proper power cord

INTERFACE - GUI

The HSX9000 Series hardware utilizes a virtual front panel as the control interface. Each unit comes with an open license to operate the application on any standard PC, including those equipped with touch screen monitors. The C++ based application GUI compliments the driver free instrument by being extremely reliable. The open DLL can also be directly accessed for control of the unit via MATLAB™, LabVIEW™, C++ code, VB code, etc.

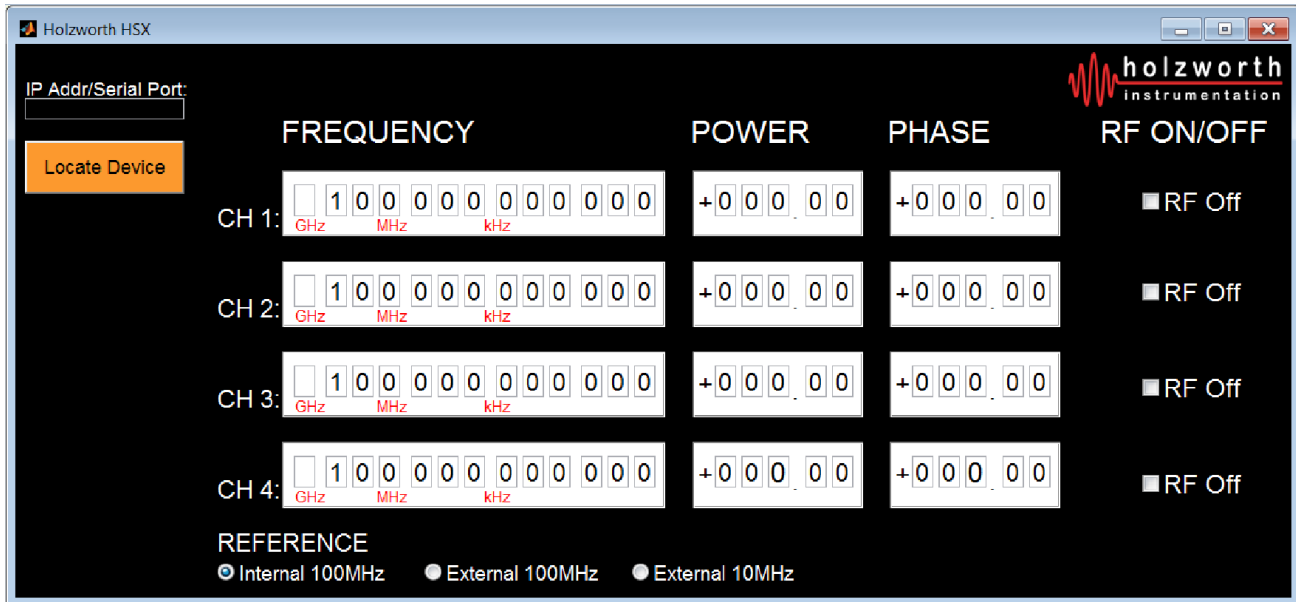

WARRANTY

All Holzworth HSX Series synthesizer products come with a standard 3 year 100% product warranty covering manufacturing defects. All product repairs and maintenance must be performed by Holzworth Instrumentation. Holzworth reserves the right to invalidate the warranty for any products that have been tampered with or used improperly. Refer to Holzworth Terms & Conditions of Sales for more details.

Holzworth products are proudly designed and manufactured in the USA.

**CONTACT INFORMATION**

Contact Holzworth directly for a product quotation, a product demonstration, or for technical inquiries.

Holzworth Instrumentation Sales Support

Phone: +1.303.325.3473 (option 1)

Email: sales@holzworth.com

Holzworth Instrumentation Technical Support

Phone: +1.303.325.3473 (option 2)

Email: support@holzworth.com

www.HOLZWORTH.com