

FEATURES

- ✓ 135mW steady state power
- ✓ 350mW start-up power
- ✓ -125dBc/Hz @ 10Hz phase noise
- ✓ 0.5ppb/g acceleration sensitivity
- ✓ Miniature Half-DIP Package

Low Power Oscillator

#blileytakesyoufurther

Description

Bliley's Half-DIP Low Power Crystal Oscillator Series offers excellent frequency versus temperature in a compact package for applications where size and power are a concern. The LP series achieves low startup power while maintaining a fast warm up of less than one minute.

Block Diagram

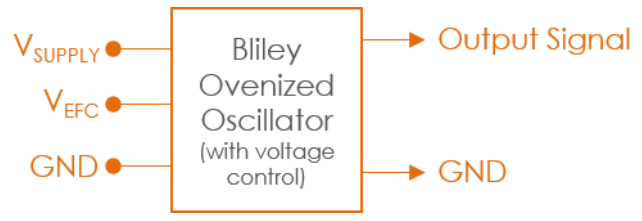

Part Number Configuration

LP - N - M - - CB

<u>Phase Noise</u>	<u>Mounting</u>	<u>Center Frequency</u>	<u>Supply Voltage</u>	<u>EFC</u>	<u>Frequency vs. Temperature***</u>	<u>Operating Range</u>
A and B (table below)	T: Through Hole S: SMT	10 MHz to 60 MHz	D: +3.3 Vdc E: +5.0 Vdc	N: N/A A: ±0.5ppm	E: ±50ppb F: ±100ppb G: ±200ppb Y: ±300ppb Z: ±75ppb	B: -20C to 70C C: -40C to 85C J: 0C to 50C

*Not all combinations of options may be possible
**Other options may be available

***See Table on page 3 for stability availability



Performance Specifications

Parameter	Conditions	Values			Unit
		MIN	TYP	MAX	
Frequency Range		10		60	MHz
Initial Tolerance	10-35MHz 36-60MHz			±100 ±200	ppb
Warm Up Time	To initial tolerance			1	Min
Frequency Stability					
vs. Temperature	See Options*** (Max) (Fmax-Fmin)/2	±50, ±75, ±100, ±200, ±300			ppb
vs. Load	± 5% Δ in Load	±25			ppb
vs. Supply Voltage	± 5% Δ in supply	±25			ppb
ADEV (Short Term Stability)	T = 1 second (10MHz)	8E-12			
Aging					
1 st Year	After 30 Days Operation	±100			ppb
20 Years		±500			ppb
Supply Voltage (Vdd)	Option D	3.13	3.3	3.47	Vdc
	Option E	4.75	5	5.25	Vdc
Power Dissipation					
Start Up	@ +25°C	350			mW
Steady State	@ +25°C, 3.3Vdc	135			mW
Steady State	@ +25°C, 5Vdc	180			mW
Electronic Frequency Control					
Voltage Range		0		Vdd	Vdc
Center Voltage	±10%	Vdd/2			Vdc
Frequency Range	See Options (Min)	±0.5			ppm
Slope		positive			
Input Impedance		100			kΩ
Linearity		10			%

*Values typical of 10MHz units

***See Table on page 3 for stability availability

DISCLAIMER: Bliley Technologies, Inc. reserves the right to make changes to the product(s) and/or information contained herein without notice. No liability is assumed as a result of their use or application. No intellectual property rights accompany the sale or delivery of any such product(s) or information.

Performance Specifications

Parameter	Conditions	Values			Unit
		MIN	TYP	MAX	
Output Characteristics (CMOS)					
High Output Level	Logic "1"	90% Vdd			Vdc
Low Output Level	Logic "0"	10% Vdd			Vdc
Rise/Fall Time			10		nSec
Duty Cycle		45	50	55	%
Load			15		pF

Parameter	Conditions	Option	Values		Unit
			TYP	TYP	
Phase Noise (CMOS)					
Phase Noise (10 MHz)	Tested at +25°C	Option	A	B	
Phase Noise (60 MHz)	Tested at +25°C	Option	A	B	

Temperature Stability Table

	Temp Range	Temp Range						Temp Range	Temp Range				
		±50	±75	±100	±200	±300			±50	±75	±100	±200	±300
10 to 35 MHz	0~50C	X	X	X	X	X	36 to 60 MHz	0~50C	N/A	X	X	X	X
	-20~70C	X	X	X	X	X		-20~70C	N/A	N/A	X	X	X
	-40~85C	N/A	X	X	X	X		-40~85C	N/A	N/A	N/A	X	X

DISCLAIMER: Bliley Technologies, Inc. reserves the right to make changes to the product(s) and/or information contained herein without notice. No liability is assumed as a result of their use or application. No intellectual property rights accompany the sale or delivery of any such product(s) or information.

Environmental Compliance

Parameter	Conditions	Values			Unit
		MIN	TYP	MAX	
Environmental & Reliability		MIN	TYP	MAX	
Operating Temperature	Option B	-20		+70	°C
	Option C	-40		+85	°C
	Option J	0		+50	°C
Storage Temperature		-55		+95	°C
Shock	MIL-STD-202 Method 213, Test Condition C	Survive			
Sinusoidal Vibration	MIL-STD-202 Method 204, Test Condition A	Survive			
Random Vibration	MIL-STD-202 Method 214, Test Condition 1B, 15min	Survive			
MTTF	Calculated using MIL-HDBK-217	153,300			Hrs
Acceleration Sensitivity	10MHz output Vibration profile: 0.001G ² /Hz 10Hz to 2kHz	0.5			ppb/g

Physical Specifications – Through Hole

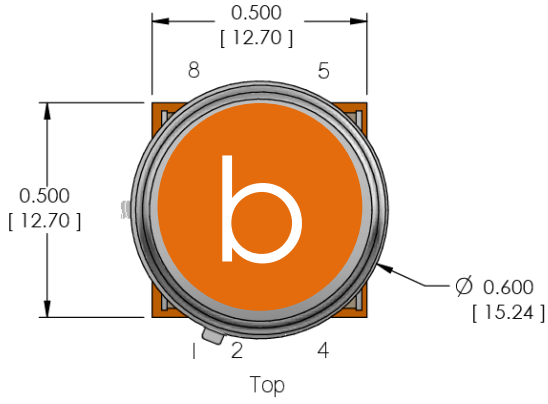

Full part number marked around side of crystal:
LPXXN-XXMXX-XXCB YYWW-SN

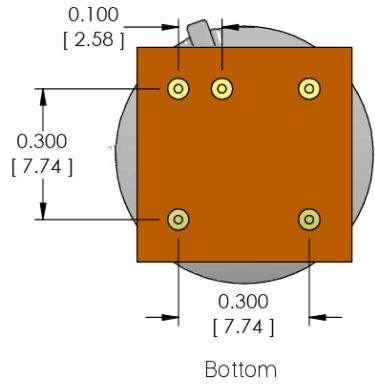
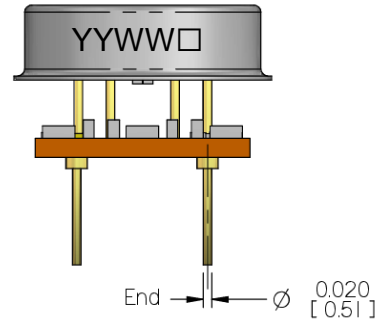
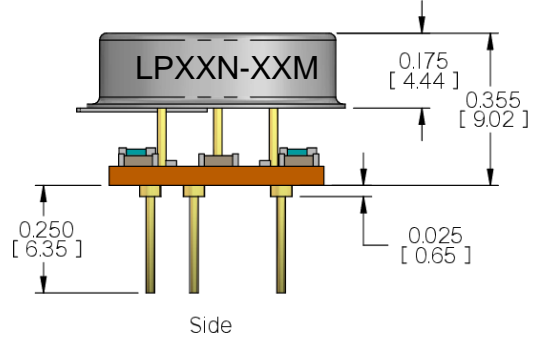
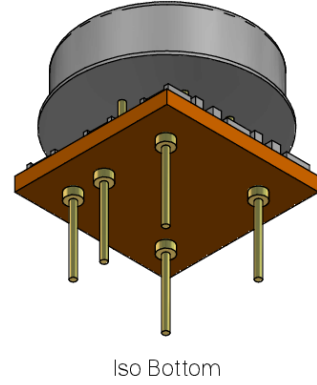

PIN	FUNCTION
1	EFC/N.C.
2	Reference Voltage/N.C.
4	Ground
5	RF Output
8	Supply Voltage

Tolerances (mm) .X = ± 0.5, .XX = ±0.2 unless otherwise specified

Notes:
• Non-RoHS available upon request

DISCLAIMER: Bliley Technologies, Inc. reserves the right to make changes to the product(s) and/or information contained herein without notice. No liability is assumed as a result of their use or application. No intellectual property rights accompany the sale or delivery of any such product(s) or information.

Physical Specifications – Surface Mount

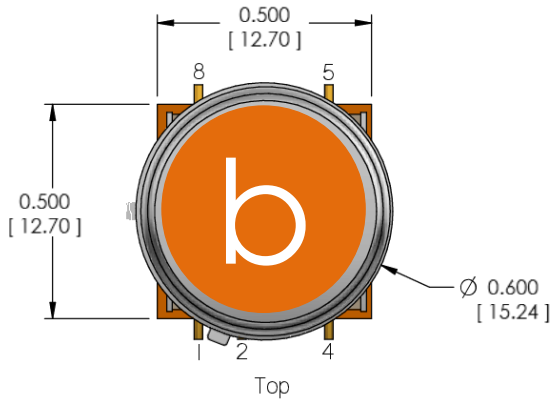

Full part number marked around side of crystal:
LPXXN-XXMXX-XXCB YYWW-SN

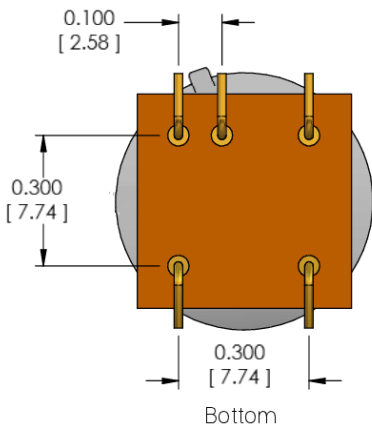
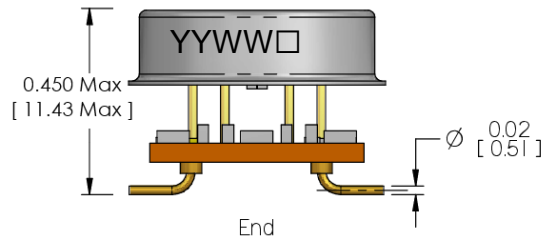
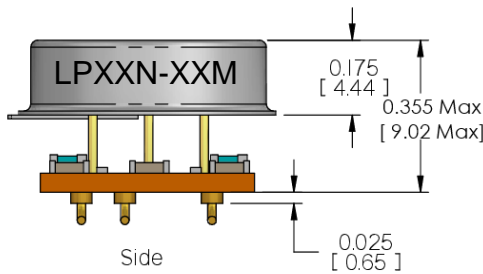
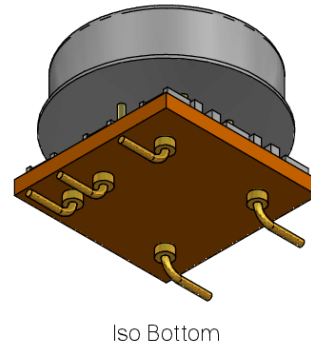

PIN	FUNCTION
1	EFC/N.C.
2	Reference Voltage/N.C.
4	Ground
5	RF Output
8	Supply Voltage

Tolerances (mm) .X = ± 0.5, .XX = ±0.2 unless otherwise specified

Notes:
• Non-RoHS available upon request