

PTRA097008NB

Thermally-Enhanced High Power RF LDMOS FET 630 W, 48 V, 920 – 960 MHz

Description

The PTRA097008NB is a 630-watt LDMOS FET intended for use in multi-standard cellular power amplifier applications in the 920 to 960 MHz frequency band. Features include input and output matching, high gain and thermally-enhanced package with earless flanges. Manufactured with Wolfspeed's advanced LDMOS process, this device provides excellent thermal performance and superior reliability.

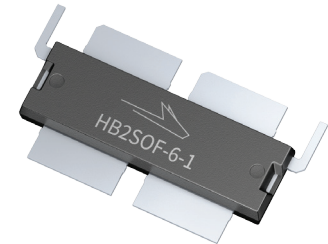

PTRA097008NB
Package PG-HB2SOF-6-1

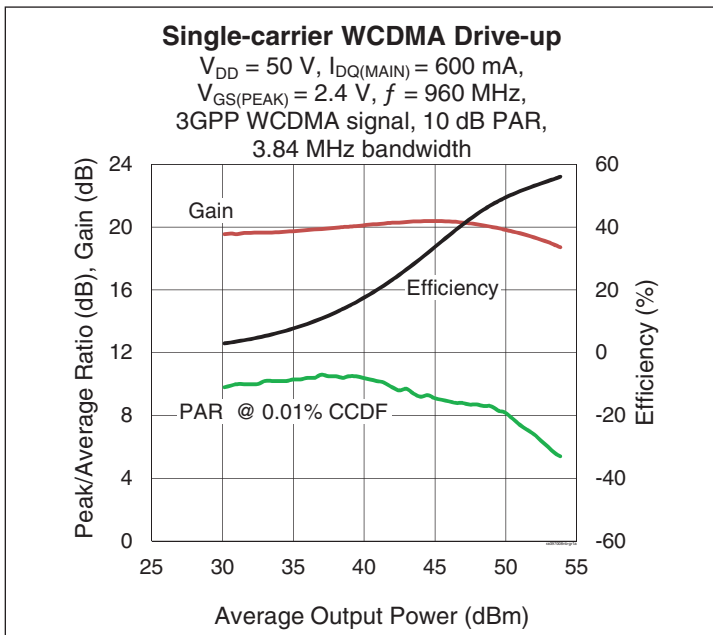

Features

- Broadband internal input and output matching
- Asymmetric design
 - Main: $P_{1dB} = 300\text{ W}$ typical
 - Peak: $P_{1dB} = 400\text{ W}$ typical
- Typical pulsed CW performance (10 μs , 10% duty cycle, class AB test), 942 MHz, 48 V, combined outputs, Doherty configuration
 - Output power at $P_{1dB} = 180\text{ W}$
 - Output power at $P_{3dB} = 600\text{ W}$
 - Efficiency = 52%
 - Gain = 19 dB
- Capable of handling 10:1 VSWR at 48 V, 89 W (CW) output power
- Integrated ESD protection
- Human Body Model Class 2 (per ANSI/ESDA/ JEDEC JS-001)
- Low thermal resistance
- Pb-free and RoHS-compliant

RF Characteristics

Single-carrier WCDMA Specifications (tested in Wolfspeed Doherty test fixture)

$V_{DD} = 50\text{ V}$, $I_{DQ} = 600\text{ mA}$, $V_{GS(PEAK)} = 2.4\text{ V}$, $P_{OUT} = 90\text{ W}$ avg, $f_1 = 960\text{ MHz}$, 3GPP signal, channel bandwidth = 3.84 MHz, peak/average = 10 dB @ 0.01% CCDF

Characteristic	Symbol	Min	Typ	Max	Unit
Gain	G_{ps}	18.25	19	—	dB
Drain Efficiency	η_D	46.5	49	—	%
Adjacent Channel Power Ratio	ACPR	—	-29	-26	dBc
Output PAR @ 0.01% CCDF	OPAR	6.0	6.8	—	dB

All published data at $T_{CASE} = 25^\circ\text{C}$ unless otherwise indicated

ESD: Electrostatic discharge sensitive device—observe handling precautions!

DC Characteristics (each side)

Characteristic	Conditions	Symbol	Min	Typ	Max	Unit
Drain-Source Breakdown Voltage	$V_{GS} = 0\text{ V}, I_{DS} = 10\text{ mA}$	$V_{(BR)DSS}$	105	—	—	V
Drain Leakage Current	$V_{DS} = 50\text{ V}, V_{GS} = 0\text{ V}$	I_{DSS}	—	—	1	μA
	$V_{DS} = 105\text{ V}, V_{GS} = 0\text{ V}$	I_{DSS}	—	—	10	μA
On-State Resistance	(Main) $V_{GS} = 10\text{ V}, V_{DS} = 0.1\text{ V}$	$R_{DS(on)}$	—	0.07	—	Ω
	(Peak) $V_{GS} = 10\text{ V}, V_{DS} = 0.1\text{ V}$	$R_{DS(on)}$	—	0.05	—	Ω
Operating Gate Voltage	(Main) $V_{DS} = 48\text{ V}, I_{DQ} = 600\text{ mA}$	V_{GS}	3	3.65	4	V
	(Peak) $V_{DS} = 48\text{ V}, I_{DQ} = 0\text{ mA}$	V_{GS}	—	2.4	—	V
Gate Leakage Current	$V_{GS} = 14\text{ V}, V_{DS} = 0\text{ V}$	I_{GSS}	—	—	1	μA

Maximum Ratings

Parameter	Symbol	Value	Unit
Drain-Source Voltage	V_{DSS}	105	V
Gate-Source Voltage	V_{GS}	-6 to +12	V
Operating Voltage	V_{DD}	0 to +55	V
Junction Temperature	T_J	225	$^{\circ}\text{C}$
Storage Temperature Range	T_{STG}	-65 to +150	$^{\circ}\text{C}$

1. Operation above the maximum values listed here may cause permanent damage. Maximum ratings are absolute ratings; exceeding only one of these values may cause irreversible damage to the component. Exposure to absolute maximum rating conditions for extended periods may affect device reliability. For reliable continuous operation, the device should be operated within the operating voltage range (V_{DD}) specified above.

2. Parameters values can be affected by end application and product usage. Values may change over time.

Thermal Characteristics

Parameter	Symbol	Value	Unit	
Thermal Resistance	Main ($T_{CASE} = 70^{\circ}\text{C}, P_{avg} = 90\text{ W CW}$)	$R_{\theta JC}$	0.45	$^{\circ}\text{C/W}$

Moisture Sensitivity Level

Level	Test Signal	Package Temperature	Unit
3	IPC/JEDEC J-STD-020	260	$^{\circ}\text{C}$

Ordering Information

Type and Version	Order Code	Package Description	Shipping
PTRA097008NB V1 R2	PTRA097008NB-V1-R2	PG-HB2SOF-6-1	Tape & Reel, 250 pcs

Typical Performance (data taken in a production test fixture)

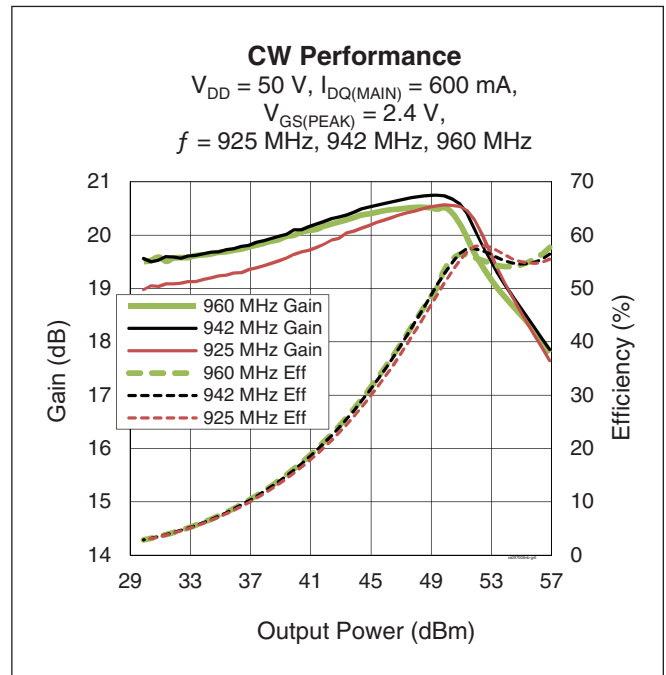
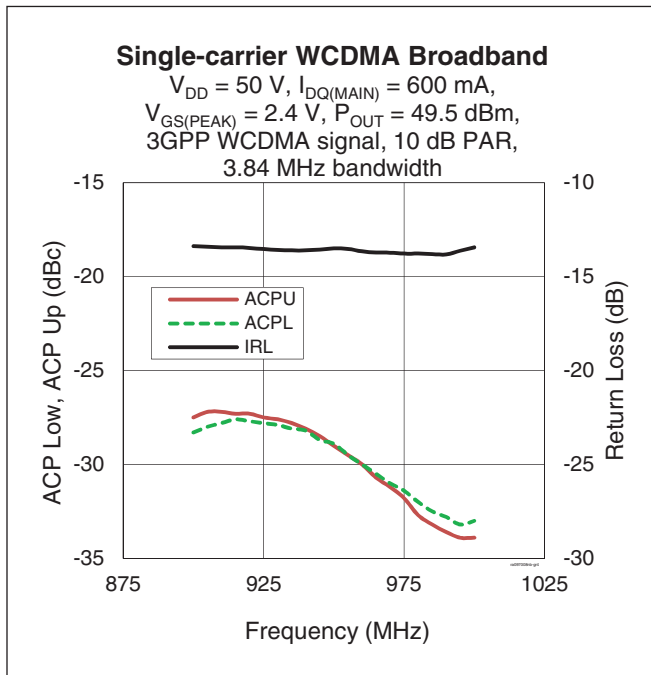
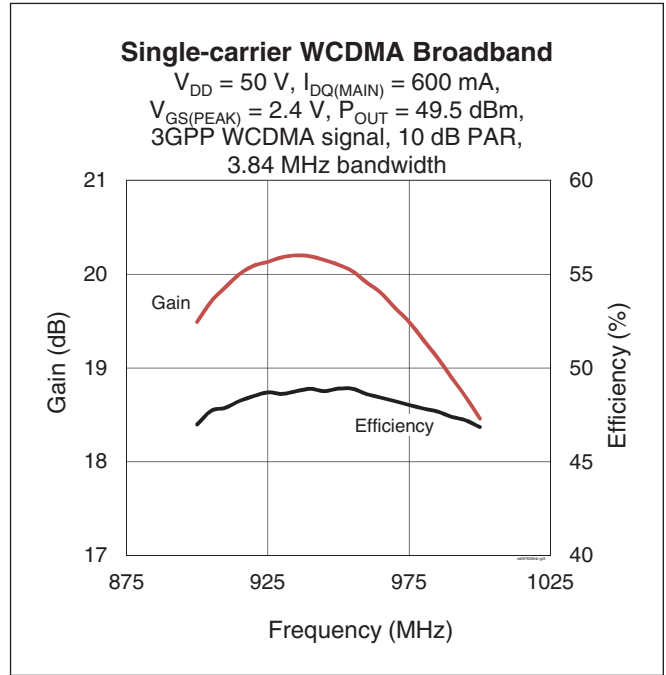
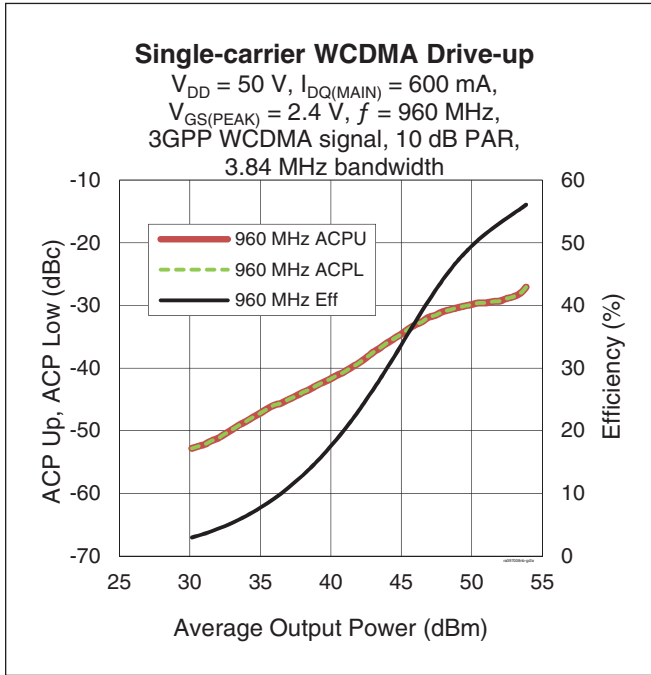



Typical Performance (cont.)

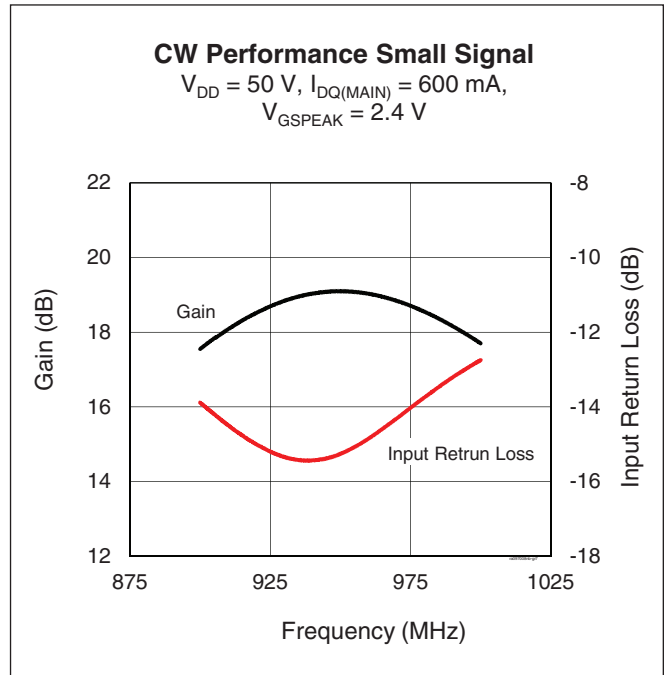
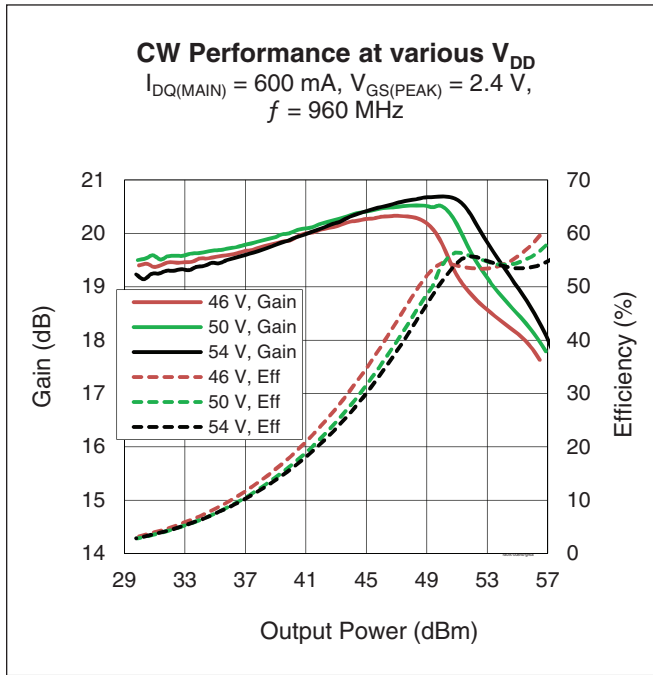

Load Pull Performance

Main Side Load Pull Performance – Pulsed CW signal – 100 μsec, 10% duty cycle, 48 V, IDQ = 600 mA, class AB

		P _{1dB}										
		Max Output Power					Max Drain Efficiency					
Freq [MHz]	Z _s [Ω]	Z _l [Ω]	Gain [dB]	P _{1dB} [dBm]	P _{1dB} [W]	η _D [%]	Z _l [Ω]	Gain [dB]	P _{1dB} [dBm]	P _{1dB} [W]	η _D [%]	
925	3.3 – j4.4	1.4 – j1.0	21.0	54.85	305	62.5	1.9 + j0.4	22.3	52.43	175	68.4	
960	2.9 – j5.1	1.1 – j1.0	20.7	54.73	297	60.0	1.8 – j0.2	22.1	53.05	201	68.5	

		P _{3dB}										
		Max Output Power					Max Drain Efficiency					
Freq [MHz]	Z _s [Ω]	Z _l [Ω]	Gain [dB]	P _{3dB} [dBm]	P _{3dB} [W]	η _D [%]	Z _l [Ω]	Gain [dB]	P _{3dB} [dBm]	P _{3dB} [W]	η _D [%]	
925	3.3 – j4.4	1.18 – j1.06	18.3	55.53	357	60.6	1.7 + j0.1	20.5	53.54	225	70.5	
960	2.9 – j5.1	1.12 – j1.22	18.6	55.40	346	59.1	1.8 – j0.2	20.1	53.80	239	70.7	

Peak Side Load Pull Performance – Pulsed CW signal – 100 μsec, 10% duty cycle, 48 V, V_{GSPK} = 3.58 V, class AB

		P _{1dB}										
		Max Output Power					Max Drain Efficiency					
Freq [MHz]	Z _s [Ω]	Z _l [Ω]	Gain [dB]	P _{1dB} [dBm]	P _{1dB} [W]	η _D [%]	Z _l [Ω]	Gain [dB]	P _{1dB} [dBm]	P _{1dB} [W]	η _D [%]	
925	3.2 – j5.9	0.7 – j0.6	20.2	56.44	440	58.0	1.2 + j0.2	21.9	53.51	224	66.3	
960	3.7 – j6.3	0.8 – j0.9	20.0	56.23	419	58.7	1.3 + j0.2	21.2	53.32	214	65.8	

		P _{3dB}										
		Max Output Power					Max Drain Efficiency					
Freq [MHz]	Z _s [Ω]	Z _l [Ω]	Gain [dB]	P _{3dB} [dBm]	P _{3dB} [W]	η _D [%]	Z _l [Ω]	Gain [dB]	P _{3dB} [dBm]	P _{3dB} [W]	η _D [%]	
925	3.2 – j5.9	0.67 – j0.64	18.2	57.17	521	60.3	1.1 – j0.2	19.6	55.81	381	67.9	
960	3.7 – j6.3	0.82 – j0.92	18.0	57.09	511	61.1	1.2 – j0.4	19.0	55.51	355	67.3	

Reference Circuit tuned for 920 to 960 MHz

DUT	PTRA097008NB-V1
Reference Circuit Part No.	LTA/PTRA097008NB-V1
PCB	Rogers 3006, 0.064 mm [.025"] thick, 2 oz. copper, $\epsilon_r = 6.50$
Find Gerber files for this reference circuit on the Wolfspeed Web site at www.wolfspeed.com/RF	

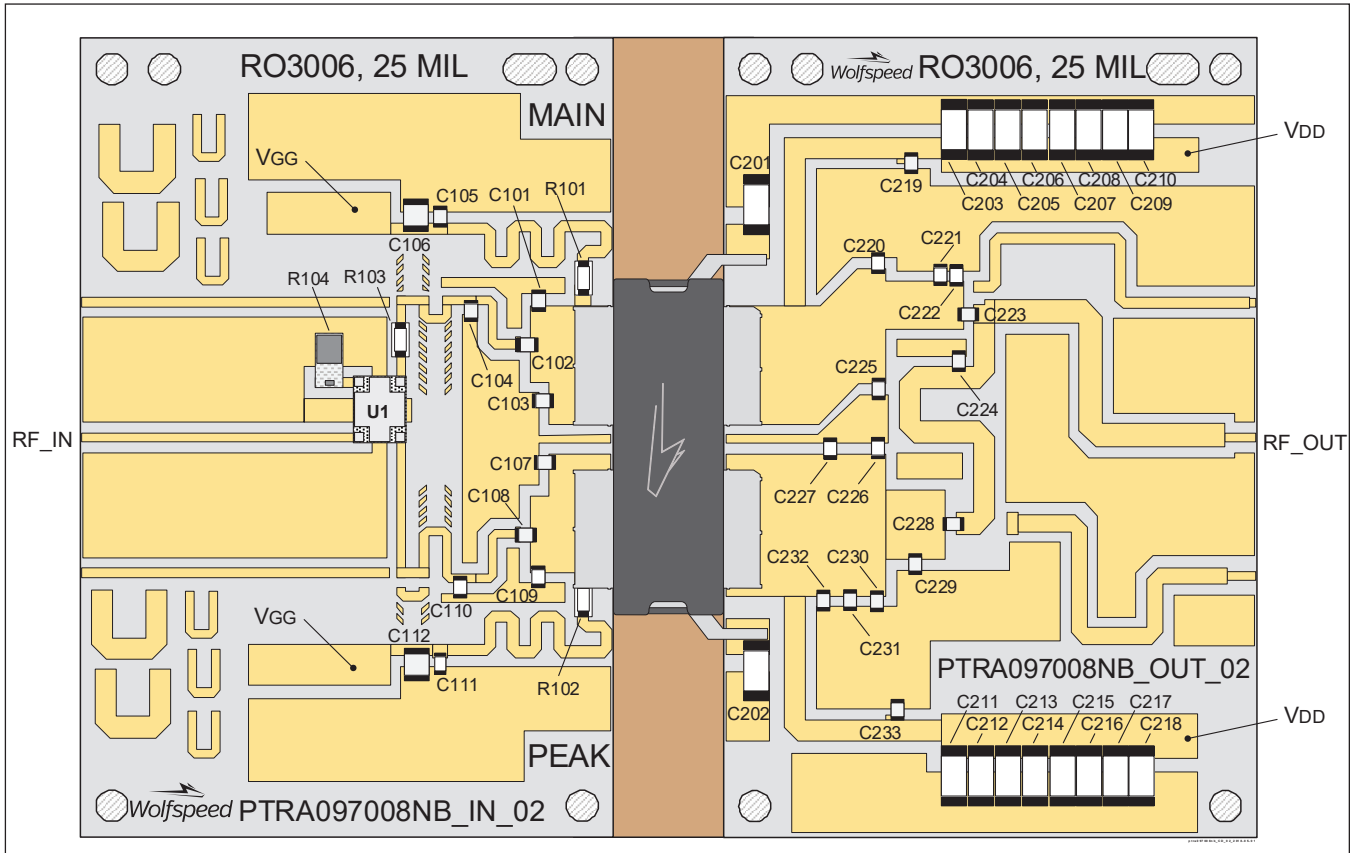

Reference circuit assembly diagram (not to scale)



Reference Circuit (cont.)

Components Information

Component	Description	Manufacturer	P/N
Input			
C101, C103, C107	Capacitor, 4.7 pF	ATC	ATC600F4R7CT250X
C102, C108	Capacitor, 36 pF	ATC	ATC600F360JT250X
C104, C109	Capacitor, 3.0 pF	ATC	ATC600F3R0CT250X
C105, C111	Capacitor, 39 pF	ATC	ATC600F390JT250X
C106, C112	Capacitor, 10 µF, 50 V	Taiyo Yuden	UMK325C7106MM-T
C110	Capacitor, 2.4 pF	ATC	ATC600F2R4CT250X
R101, R102, R103	Chip resistor, 5.1 ohms	Panasonic	ERJ-8GEYJ5R1V
R104	Resistor, 50 ohms	Richardson	C16A50Z4
U1	Hybrid coupler	Anaren	X3C09P1-03S
Output			
C201, C202, C203, C204, C205, C206, C207, C208, C209, C210, C211, C212, C213, C214, C215, C216, C217, C218	Capacitor, 10 µF, 100 V	TDK Corporation	C5750X7S2A106M230KB
C219, C228, C233	Capacitor, 39 pF	ATC	ATC600F390JT250X
C220, C224, C225	Capacitor, 3.3 pF	ATC	ATC600F3R3CT250X
C221	Capacitor, 0.3 pF	ATC	ATC600F0R3CT250X
C222	Capacitor, 1.2 pF	ATC	ATC600F1R2CT250X
C223	Capacitor, 12 pF	ATC	ATC600F120JT250X
C226	Capacitor, 5.1 pF	ATC	ATC600F5R1CT250X
C227	Capacitor, 8.2 pf	ATC	ATC600F8R2CT250X
C229	Capacitor, 1.0 pF	ATC	ATC600F1R0CT250X
C230, C231	Capacitor, 2.0 pF	ATC	ATC600F2R0CT250X
C232	Capacitor, 7.5 pF	ATC	ATC600F7R5CT250X

Pinout Diagram (top view)

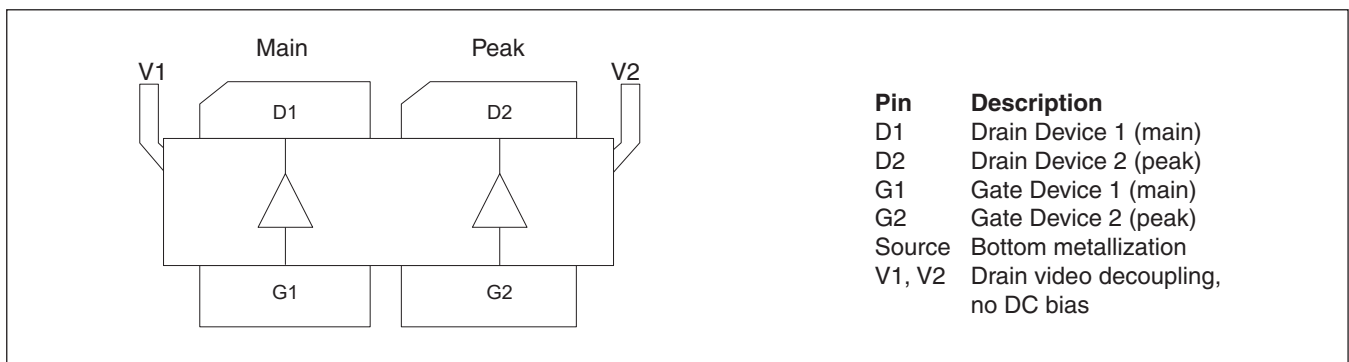

Package Outline Specifications

Package PG-HB2SOF-6-1 (top and side views)

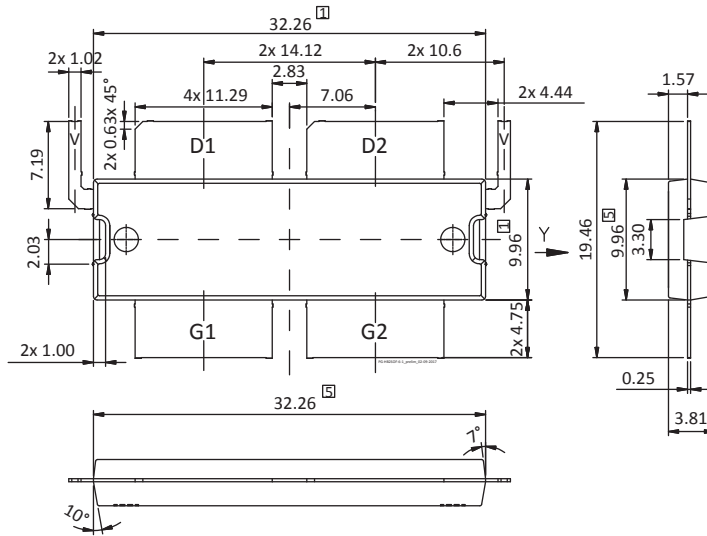

Diagram Notes—unless otherwise specified:

1. Mold/dam bar/metal protrusion of 0.30 mm max per side not included
2. Fillets and radii: all radii are 0.30t mm max
3. Interpret dimensions and tolerances per ISO 8015
4. Dimensions are mm
5. Does not include mold/dam bar and metal protrusion
6. All tolerances ± 0.1 mm
7. All metal surfaces tin pre-plated, except area of cut
8. Lead thickness: 0.25 mm
9. Pins: D1, D2 – drain; G1, G2 – gate; Source – bottom metallization; V – drain video decoupling, no DC bias

Package Outline Specifications

Package PG-HB2SOF-6-1 (bottom view)

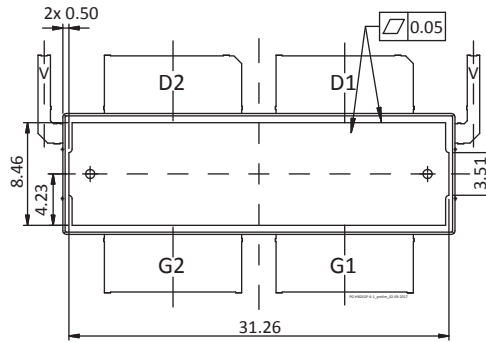

Diagram Notes—unless otherwise specified:

1. Mold/dam bar/metal protrusion of 0.30 mm max per side not included
2. Fillets and radii: all radii are 0.30t mm max
3. Interpret dimensions and tolerances per ISO 8015
4. Dimensions are mm
5. Does not include mold/dam bar and metal protrusion
6. All tolerances ± 0.1 mm
7. All metal surfaces tin pre-plated, except area of cut
8. Lead thickness: 0.25 mm
9. Pins: D1, D2 – drain; G1, G2 – gate; Source – bottom metallization;
V – drain video decoupling, no DC bias



Revision History

Revision	Date	Data Sheet	Page	Subjects (major changes at each revision)
01	2017-03-01	Advance	all	Proposed specification for new product development
02	2018-01-26	Production	all	Product released to production—Data Sheet now includes updated specifications, performance graphs, and reference circuit information.
03	2018-05-01	Production	All, 2	Converted to Wolfspeed Data Sheet, updated ordering code
03.1	2019-03-06	Production	2	Added MSL table

For more information, please contact:

4600 Silicon Drive
 Durham, North Carolina, USA 27703
www.wolfspeed.com/RF

Sales Contact
RFSales@wolfspeed.com

RF Product Marketing Contact
RFMarketing@wolfspeed.com
 919.407.7816

Notes

Disclaimer

Specifications are subject to change without notice. Cree, Inc. believes the information contained within this data sheet to be accurate and reliable. However, no responsibility is assumed by Cree for any infringement of patents or other rights of third parties which may result from its use. No license is granted by implication or otherwise under any patent or patent rights of Cree. Cree makes no warranty, representation or guarantee regarding the suitability of its products for any particular purpose. “Typical” parameters are the average values expected by Cree in large quantities and are provided for information purposes only. These values can and do vary in different applications and actual performance can vary over time. All operating parameters should be validated by customer’s technical experts for each application. Cree products are not designed, intended or authorized for use as components in applications intended for surgical implant into the body or to support or sustain life, in applications in which the failure of the Cree product could result in personal injury or death or in applications for planning, construction, maintenance or direct operation of a nuclear facility.